

STORIA HISTORY

Binova è un'azienda che da oltre 60 anni rappresenta un'eccellenza nel mercato delle cucine di alta gamma. Nel corso della sua lunga storia, il marchio ottiene innumerevoli premi internazionali. Tali riconoscimenti valorizzano la naturale attitudine del brand a proiettarsi sempre in avanti, attraverso brevetti che rivoluzionano convinzioni radicate e mediante invenzioni che anticipano i trend e semplificano notevolmente l'abitare. Binova nasce nel 1958 all'interno del laboratorio di Giovanni e Francesco Bolletta, due giovanissimi falegnami di Petriignano d'Assisi, che integrano il saper fare artigianale con innovazioni tecnologiche provenienti dal mondo automobilistico americano. Ben presto, da semplice bottega l'azienda si trasforma in una realtà industriale che contribuisce a scrivere la storia del design mondiale. Le collezioni Binova, nate da una ricerca progettuale continua, sono caratterizzate da prodotti assolutamente innovativi e rivoluzionari che si distinguono per una straordinaria attenzione ai dettagli e una cura unica e impareggiabile per la qualità. Nel 2016 Inizia un nuovo capitolo della storia di Binova con il passaggio al gruppo Cubo Design, affermata realtà abruzzese guidata da Antonio Arangiario. L'industriale vanta una consolidata esperienza nel settore delle cucine componibili che gli ha permesso di imporsi come protagonista assoluto nel comparto legno-arredo. Dotato di una lungimirante cultura imprenditoriale e di una innata sensibilità nel percepire le esigenze del mercato e prevedere i mutamenti dello stile, dà al marchio nuova linfa e una forte identità. Consistenti investimenti si affiancano a un'incessante attività di ricerca e sviluppo, mantenendo sempre intatti sia il know-how tecnologico, sia il carattere ricercato e il design tipicamente italiano dal sapore contemporaneo che hanno decretato il successo del brand. Grazie all'attuale corso aziendale, forme e materiali innovativi entrano a far parte dell'heritage Binova e nascono collezioni in grado di soddisfare i più alti standard estetici. Nel 2017, Binova continua la propria crescita inarrestabile con l'apertura del primo flagship store nel distretto del design milanese con una superficie espositiva di ben 350 m2. Il 2019 è invece l'anno della trasformazione a livello produttivo, dal momento che viene inaugurato Factory-One, avanguardistico stabilimento del marchio in cui si lavora ogni componente a partire da zero, garantendo massimo controllo qualitativo e possibilità di personalizzazione dei prodotti illimitate. Nel 2021 avviene il lancio dell'attesissimo sistema casa, un progetto integrato caratterizzato da collezioni non più destinate unicamente all'arredamento dell'ambiente cucina ma che, in un continuum di finiture, abbracciano la zona giorno, giungendo a contaminare persino strutture architettoniche portanti come i pilastri, per una casa in total look Binova che rappresenta il segno dell'ascesa continua del marchio.

Binova is a company that has represented excellence in the high-end kitchen market for over 60 years. Throughout its long history, the brand has won countless international awards. These awards enhance the brand's natural attitude to always project itself forward, through patents that revolutionize deep-rooted convictions and through inventions that anticipate trends and greatly simplify living. Binova was born in 1958 in the laboratory of Giovanni and Francesco Bolletta, two very young carpenters from Petriignano d'Assisi, who integrate craftsmanship with technological innovations from the American automotive world. Soon, from a simple workshop, the company turns into an industrial reality that contributes to writing the history of world design. The Binova collections, born from a continuous design research, are characterized by absolutely innovative and revolutionary products that are distinguished by an extraordinary attention to detail and a unique and unparalleled attention to quality. 2016 A new chapter in the history of Binova begins with the passage to the Cubo Design group, an established Abruzzo company led by Antonio Arangiario. The industrialist boasts a consolidated experience in the modular kitchen sector that has allowed him to establish himself as the absolute protagonist in the wood-furniture sector. Equipped with a far-sighted entrepreneurial culture and an innate sensitivity in perceiving the needs of the market and foreseeing changes in style, he gives the brand new life and a strong identity. Substantial investments go hand in hand with incessant research and development, always keeping intact both the technological know-how and the refined character and typically Italian design with a contemporary flavor that have made the brand successful. Thanks to the current company course, innovative shapes and materials become part of the Binova heritage and collections able to meet the highest aesthetic standards are born. In 2017, Binova continues its unstoppable growth with the opening of the first flagship store in the Milanese design district with an exhibition area of 350 m2. 2019, on the other hand, is the year of transformation at the production level, since Factory-One is inaugurated, the brand's avant-garde factory in which each component is processed starting from scratch, guaranteeing maximum quality control and unlimited product customization possibilities. In 2021 the highly anticipated home system is launched, an integrated project characterized by collections no longer intended solely for furnishing the kitchen environment but which, in a continuum of finishes, embrace the living area, even contaminating load-bearing architectural structures such as the pillars, for a house in a Binova total look that represents the sign of the continuous rise of the brand.



INNOVAZIONE 4.0 INNOVATION 4.0

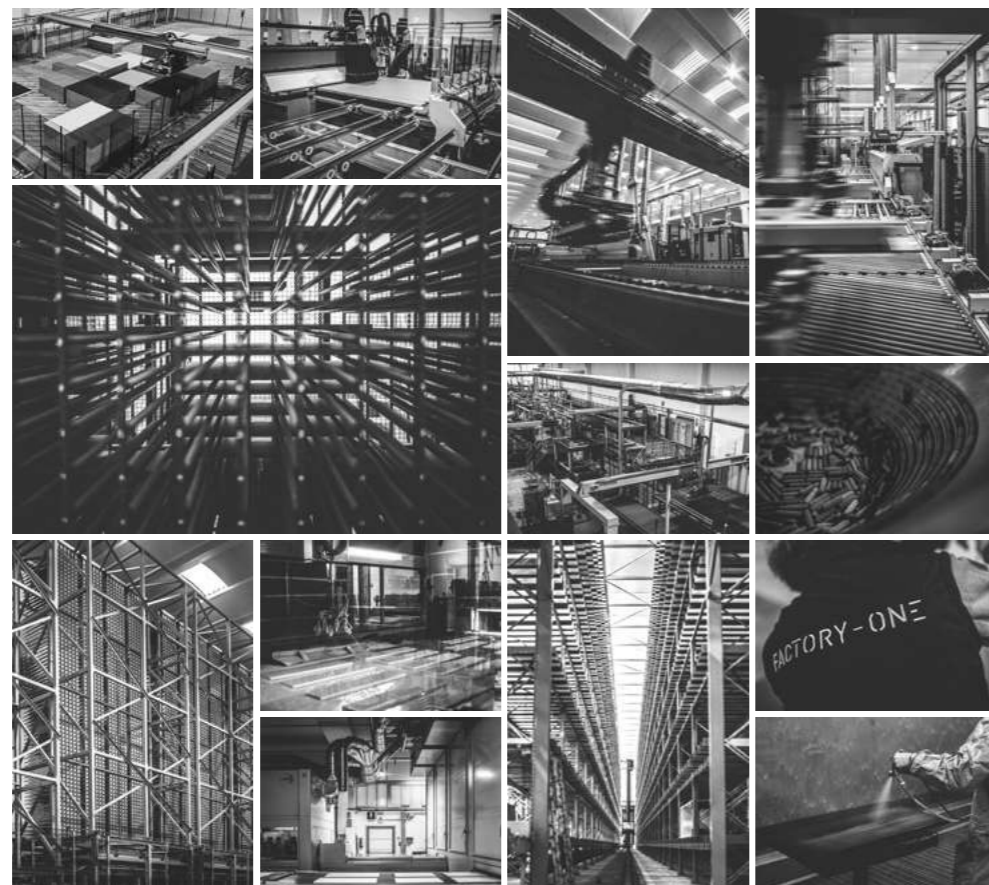

Il 2018 ha il sapore di un vero e proprio passo epocale per Cubo Design. Viene attuata una riorganizzazione radicale dei suoi asset principali, attraverso un'interpretazione del futuro ispirata ad efficienza, efficacia e rispetto dell'ambiente, che nel nuovo polo di 25.000 m² trovano concretezza grazie a soluzioni tecniche, informatiche ed energetiche, totalmente integrate: nasce Factory-One. Una struttura avveniristica, in cui la produzione di cucine viene affrontata e risolta con sistemi intelligenti, attraverso l'integrazione totale tra processi e controllo umano. Un percorso con andamento lineare e non più ad isole di lavoro, costituito da macchinari altamente tecnologici, interconnessi e contraddistinti da assoluta precisione, costantemente garantita mediante il controllo effettuato da manodopera specializzata. Appositi sensori che sfruttano il collegamento alla rete, permettono di monitorare le varie fasi della lavorazione industriale e di conoscere in tempo reale lo status delle apparecchiature su cui sono collegati. Un sistema d'eccellenza, in cui il concetto di industry 4.0 viene implementato in modo completo, divenendo propulsore del business di Cubo Design.

2018 has the flavor of a real epochal step for Cubo Design. A radical reorganization of its main assets is implemented, through an interpretation of the future inspired by efficiency, effectiveness and respect for the environment, which in the new pole of 25.000 m² are concretized thanks to fully integrated technical, IT and energy solutions: Factory-One is born. A futuristic structure, in which the production of kitchens is addressed and resolved with intelligent systems, through the total integration between processes and human control. A route with a linear progress and no longer with work islands, made up of highly technological machinery, interconnected and characterized by absolute precision, constantly guaranteed through the control carried out by skilled labor. Special sensors that exploit the connection to the network, allow you to monitor the various stages of industrial processing and to know in real time the status of the equipment on which they are connected. A system of excellence, in which the concept of industry 4.0 is fully implemented, becoming the driving force behind Cubo Design's business.

COLLEZIONI COLLECTIONS



08
25

AVOLA LEGNO



26
43

BLUNA LACCATO LUCIDO



44
57

MANTIS + LAB



58
69

REGULA + BLUNA



BLUNA METAL 4.0

70
83



84
95

AVOLA GRES



MANTIS + BLUNA

96
109



110
121

REFLEX + VOGUE



BLUNA LEGNO

122
133



BLUNA TECH BRUNITO

146
157



BLUNA TECH CHAMPAGNE

158
169



134
145

VOGUE + BLUNA

8

9

AVOLA LEGNO



AVOLA LEGNO

11

Un progetto che si pone l'obiettivo di dare libertà totale ai materiali, di poter coesistere e di essere raccolti in un unico insieme determinato dal telaio in alluminio Avola in grado di abbracciare il legno, il vetro ed il gres nello stesso momento. Lo spazio si delinea partendo da una prospettiva centrale che sviluppa due grandi pareti, ciascuna con differenti funzioni. A destra una parete living caratterizzata da volumi a sbalzo che si intersecano tra loro, le basi a terra fungono da contenitori e appoggio per la tv, un piano sospeso in legno utile come spazio di lavoro temporaneo, boiserie con mensole illuminate e colonne dall'ampio contenimento alleggerite dal sistema L+1.5. A sinistra una madia Avola con ante riflettenti per una completa integrazione nello spazio ed una parete con ante retrattili attrezzata per consentire uno spazio home working ottimale. Al centro si sviluppa la zona conviviale con tavolo, divano e coffee table. A project that aims to give total freedom to materials, to be able to coexist and be collected in a single whole determined by the Avola aluminum frame capable of embracing wood, glass and gres at the same time. The space is outlined starting from a central perspective that develops two large walls, each with different functions. On the right, a living wall characterized by cantilevered volumes that intersect each other, the lower bases allow storage and support for the TV, a suspended wooden top useful as a temporary work space, boiserie with illuminated shelves and columns with shelves lightened by the L+1.5 system. On the left, an Avola sideboard with reflective doors for complete integration into the space and a wall with retractable doors equipped to allow an optimal home working space. At the center is the convivial area with table, sofa and coffee table.





14

15



**DETTAGLIO TAVOLO
MOOR 02, BASAMENTO
IN LEGNO FRASSINO
CARBONE E PIANO
IN GRES VERDE
BORGOGNA LUCIDO.**

**DETAIL OF MOOR 02
TABLE, BASE IN WOOD
FRASSINO CARBONE
FINISH AND TOP IN
GRES VERDE BORGOGNA
GLOSSY FINISH.**

**DETAIL OF MOOR 02
TABLE, BASE IN WOOD
FRASSINO CARBONE
FINISH AND TOP IN
GRES VERDE BORGOGNA
GLOSSY FINISH.**

**DETAIL OF MOOR 02
TABLE, BASE IN WOOD
FRASSINO CARBONE
FINISH AND TOP IN
GRES VERDE BORGOGNA
GLOSSY FINISH.**





18

19

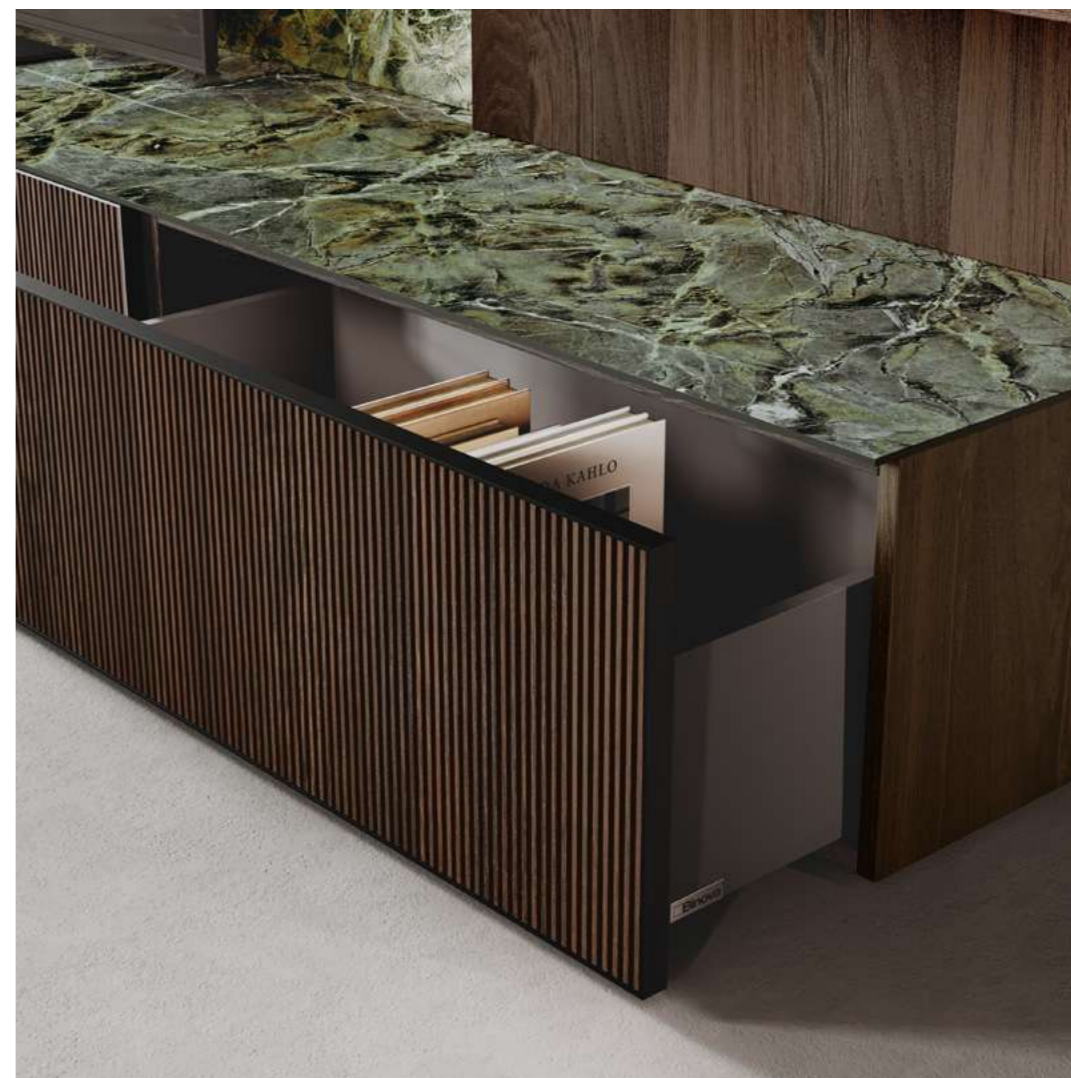

DETTAGLIO PARETE
LIVING, BASI BASSE
AVOLA LEGNO ROVERE
TERMOTRATTATO E
TELAIO NERO, TOP GRES
VERDE BORGOGNA
LUCIDO, BOISERIE
LEGNO ROVERE
TERMOTRATTATO,
COLONNE BLUNA
LACCATO METAL 4.0
FINITURA PELTRO.

LIVING WALL DETAIL,
LOWER BASES AVOLA
WOOD ROVERE
TERMOTRATTATO FINISH
AND BLACK FRAME,
TOP GRES VERDE
BORGOGNA GLOSSY
FINISH, BOISERIE WOOD
ROVERE TERMOTRATTATO
FINISH, BLUNA COLUMNS
LACQUERED METAL 4.0
PELTRO FINISH.

LIVING WALL DETAIL,
LOWER BASES AVOLA
WOOD ROVERE
TERMOTRATTATO FINISH
AND BLACK FRAME,
TOP GRES VERDE
BORGOGNA GLOSSY
FINISH, BOISERIE WOOD
ROVERE TERMOTRATTATO
FINISH, BLUNA COLUMNS
LACQUERED METAL 4.0
PELTRO FINISH.

LIVING WALL DETAIL,
LOWER BASES AVOLA
WOOD ROVERE
TERMOTRATTATO FINISH
AND BLACK FRAME,
TOP GRES VERDE
BORGOGNA GLOSSY
FINISH, BOISERIE WOOD
ROVERE TERMOTRATTATO
FINISH, BLUNA COLUMNS
LACQUERED METAL 4.0
PELTRO FINISH.



DETTAGLIO
COLONNE HOME
WORKING CON ANTE
RIENTRANTI BLUNA
LACCATO METAL 4.0
PELTRO. BOISERIE
LEGNO ROVERE
TERMOTRATTATO.

DETAIL OF HOME
WORKING COLUMNS
WITH RETRACTABLE
DOORS BLUNA
LACQUERED METAL
4.0 PELTRO FINISH.
BOISERIE WOOD ROVERE
TERMOTRATTATO FINISH.

DETAIL OF HOME
WORKING COLUMNS
WITH RETRACTABLE
DOORS BLUNA
LACQUERED METAL
4.0 PELTRO FINISH.
BOISERIE WOOD ROVERE
TERMOTRATTATO FINISH.

DETAIL OF HOME
WORKING COLUMNS
WITH RETRACTABLE
DOORS BLUNA
LACQUERED METAL
4.0 PELTRO FINISH.
BOISERIE WOOD ROVERE
TERMOTRATTATO FINISH.

DETTAGLIO MADIA
AVOLA CON TELAIO
NERO OPACO E VETRO
STOPSOL FUME'.
BASAMENTO ROUND
IN METALLO FINITURA
NERO OPACO.

DETAIL OF AVOLA
SIDEBOARD WITH
MATT BLACK FRAME
AND STOPSOL FUME'
GLASS. ROUND LOWER
STRUCTURE METAL
MATT BLACK FINISH.

DETAIL OF AVOLA
SIDEBOARD WITH
MATT BLACK FRAME
AND STOPSOL FUME'
GLASS. ROUND LOWER
STRUCTURE METAL
MATT BLACK FINISH.

DETAIL OF AVOLA
SIDEBOARD WITH
MATT BLACK FRAME
AND STOPSOL FUME'
GLASS. ROUND LOWER
STRUCTURE METAL
MATT BLACK FINISH.



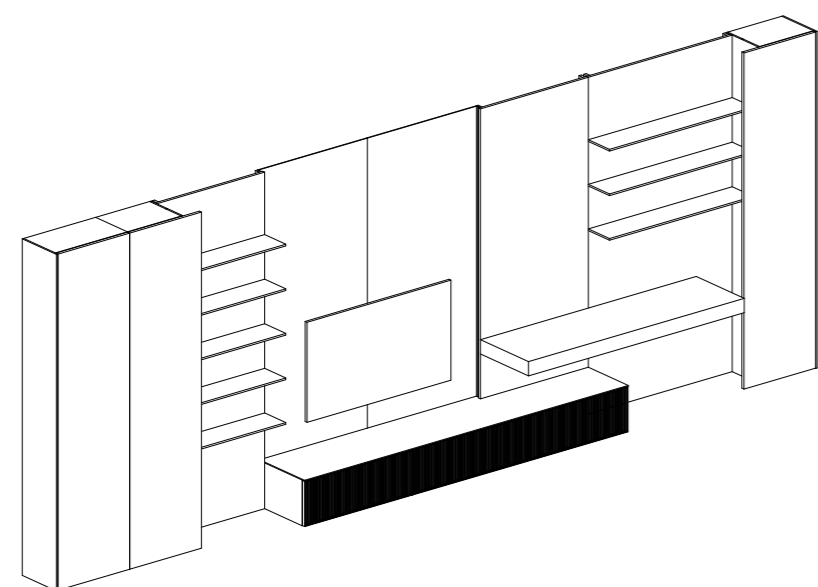

PARETE LIVING LIVING WALL

L 635 H 235,5 P 47,5

BLUNA LACCATO METAL 4.0 PELTRO
 AVOLA LEGNO RIGATO ROVERE TERMOTRATTATO
 CON TELAIO NERO OPACO
 SCHIENALE GRES VERDE BORGOGNA LUCIDO

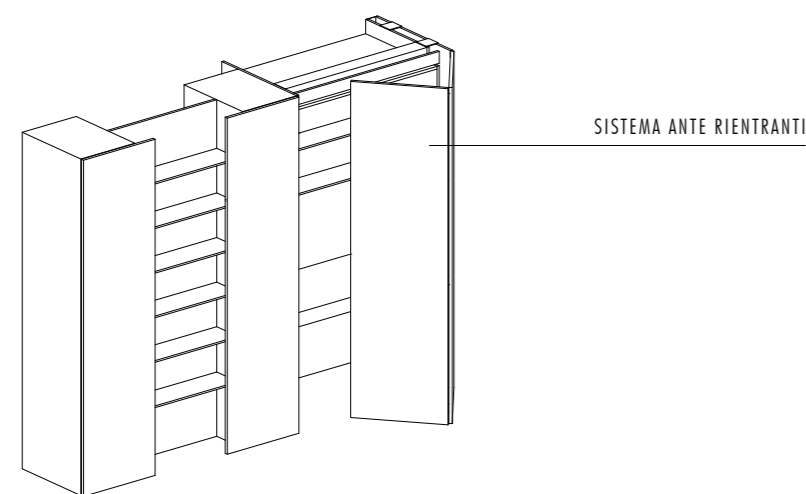

PARETE STUDIO HOME WORKING WALL

L 310 CM H 235,5 P 80

BLUNA LACCATO METAL 4.0 PELTRO
 AVOLA LEGNO RIGATO ROVERE TERMOTRATTATO
 CON TELAIO NERO OPACO

AVOLA LEGNO

**SCHEDA TECNICA DATA SHEET
 FICHE TECHNIQUE FICHA DE DATOS**

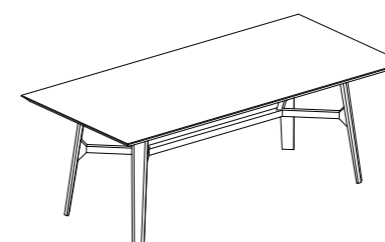

TAVOLO MOOR 02 TABLE

L. 200 H. 76 P. 100

TOP GRES VERDE BORGOGNA LUCIDO
 STRUTTURA LEGNO FRASSINO CARBONE E
 SOTTOPIANA LACCATO OPACO NERO TRAFFICO

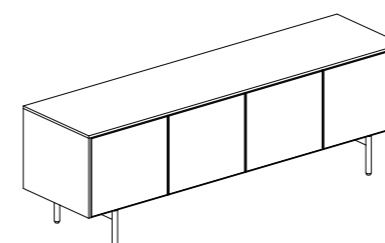

MADIA SIDEBOARD

L. 183 H. 62,2 P. 47,5

AVOLA VETRO STOPSOL SPECCHIO FUMÈ CON TELAIO NERO
 STRUTTURA INTERNA LACCATO OPACO ROSSO TOSCA
 TOP E FIANCHI LEGNO ROVERE TERMOTRATTATO
 BASAMENTO ROUND METALLO NERO OPACO

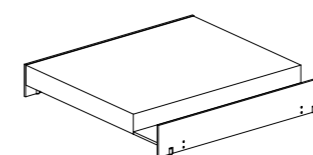

TAVOLO DA CAFFÈ COFFEE TABLE

L. 100 H. 16 P. 100

TOP ALTO LEGNO ROVERE TERMOTRATTATO
 TOP SOTTILE GRES VERDE BORGOGNA LUCIDO
 STRUTTURA METALLO NERO OPACO

26

27

BLUNA LACCATO LUCIDO



BLUNA LACCATO LUCIDO

29

La trasversalità del modello Bluna è espressa in questo ambiente mediante una sapiente miscela di materiali riflettenti e superfici materiche per un connubio unico. Gli arredi di questo spazio si sviluppano attorno ad una parete di forma sinusoidale e determinato uno spazio vivibile a 360°. Nella prima area si sviluppa un angolo living costituito a destra da vetrine con funzione bar per poi proseguire con basi basse in laccato lucido con sistema zenit e boiserie leaf con mensole sfalsate. La parete prosegue con colonne che si ricordano ad una zona cucina con ante retrattili di modo da confondersi in uno spazio lineare e fluido. A completare lo spazio intervengono la madia ed in coffe table sempre nelle stesse finiture. The transversality of the Bluna model is expressed in this environment by a wise mixture of reflective materials and material surfaces for a unique connubio. The furnishings of this space develop around a sinusoidal wall and determined a livable 360° space. In the first area there is a living angle consisting of the right from showcases with bar function and then continue with low bases in glossy lacquered with zenit system and leaf boiserie with staggered shelves. The wall continues with columns that are linked to a kitchen area with retractable doors so as to be confused in a linear and fluid space. To complete the space spoke the sideboard and in coffe table always in the same finishes.





32

33



DETTAGLIO COLONNA
BAR CON ANTE MILES
IN VETRO FUME' E
TELAIO IN FINITURA
ALLUMINIO NERO.
BASI BASSE FINITURA
LACCATO LUCIDO
CARRUBA, PIANO
E SCHIENALE GRES
FINITURA OROBICO
DARK LUCIDO.

DETAIL OF BAR
COLUMN WITH MILES
DOORS MADE IN
FUME' GLASS AND
BLACK ALUMINUM
FRAME. LOWER
UNIT IN GLOSSY
LACQUERED CARRUBA
FINIS, TOP AND
BACK PANEL IN GRES
OROBICO DARK FINISH.

DETAIL OF BAR
COLUMN WITH MILES
DOORS MADE IN
FUME' GLASS AND
BLACK ALUMINUM
FRAME. LOWER
UNIT IN GLOSSY
LACQUERED CARRUBA
FINIS, TOP AND
BACK PANEL IN GRES
OROBICO DARK FINISH.

DETAIL OF BAR
COLUMN WITH MILES
DOORS MADE IN
FUME' GLASS AND
BLACK ALUMINUM
FRAME. LOWER
UNIT IN GLOSSY
LACQUERED CARRUBA
FINIS, TOP AND
BACK PANEL IN GRES
OROBICO DARK FINISH.





DETTAGLIO ZONA CUCINA CON ANTE RETRATTILI IN FINITURA BILAMINATO LEGNO ROVERE QUERCIA. TAVOLO MOOR 04 CON STRUTTURA IN FRASSINO CARBONE E PIANO IN GRES OROBICO DARK LUCIDO.

DETAIL OF KITCHEN AREA WITH RETRACTABLE DOORS IN BILAMINATE ROVERE QUERCIA FINISH. MOOR 04 TABLE WITH STRUCTURE FRASSINO CARBONE FINISH AND TOP IN GRES OROBICO DARK FINISH.

DETAIL OF KITCHEN AREA WITH RETRACTABLE DOORS IN BILAMINATE ROVERE QUERCIA FINISH. MOOR 04 TABLE WITH STRUCTURE FRASSINO CARBONE FINISH AND TOP IN GRES OROBICO DARK FINISH.

DETAIL OF KITCHEN AREA WITH RETRACTABLE DOORS IN BILAMINATE ROVERE QUERCIA FINISH. MOOR 04 TABLE WITH STRUCTURE FRASSINO CARBONE FINISH AND TOP IN GRES OROBICO DARK FINISH.



DETTAGLIO ZONA
CUCINA CON ANTE
RETRATTILI IN
FINITURA BILAMINATO
LEGNO ROVERE
QUERCIA. MODULI
INTERNI TECH
FINITURA ALLUMINIO
BRUNITO CON GOLA
EMME NERO OPACO E
TOP IN GRES FINITURA
OROBICO DARK.

DETAIL OF KITCHEN
AREA WITH
RETRACTABLE DOORS
IN BILAMINATE ROVERE
QUERCIA FINISH.
INTERNAL MODULES
IN TECH ALLUMINIO
BRUNITO FINISH WITH
EMME GROOVE MATT
BLACK FINISH AND
TOP IN GRES OROBICO
DARK FINISH.

DETAIL OF KITCHEN
AREA WITH
RETRACTABLE DOORS
IN BILAMINATE ROVERE
QUERCIA FINISH.
INTERNAL MODULES
IN TECH ALLUMINIO
BRUNITO FINISH WITH
EMME GROOVE MATT
BLACK FINISH AND
TOP IN GRES OROBICO
DARK FINISH.

DETAIL OF KITCHEN
AREA WITH
RETRACTABLE DOORS
IN BILAMINATE ROVERE
QUERCIA FINISH.
INTERNAL MODULES
IN TECH ALLUMINIO
BRUNITO FINISH WITH
EMME GROOVE MATT
BLACK FINISH AND
TOP IN GRES OROBICO
DARK FINISH.





40

41



DETTAGLIO MADIA
IN LACCATO LUCIDO
CARRUBA. TOP GRES
OROBICO DARK
LUCIDO. BASAMENTO
CUT BRONZO OPACO.
STRUTTURA INTERNA
LACCATO OPACO
FINITURA BLU OCEANO.

DETAIL OF SIDEBOARD
GLOSSY LACQUERED
CARRUBA FINISH. TOP
IN GRES OROBICO
DARK FINISH. CUT
BASE BRONZE FINISH.
INTERNAL STRUCTURE
MATT LACQUERED BLU
OCEANO FINISH.

DETAIL OF SIDEBOARD
GLOSSY LACQUERED
CARRUBA FINISH. TOP
IN GRES OROBICO
DARK FINISH. CUT
BASE BRONZE FINISH.
INTERNAL STRUCTURE
MATT LACQUERED BLU
OCEANO FINISH.

DETAIL OF SIDEBOARD
GLOSSY LACQUERED
CARRUBA FINISH. TOP
IN GRES OROBICO
DARK FINISH. CUT
BASE BRONZE FINISH.
INTERNAL STRUCTURE
MATT LACQUERED BLU
OCEANO FINISH.

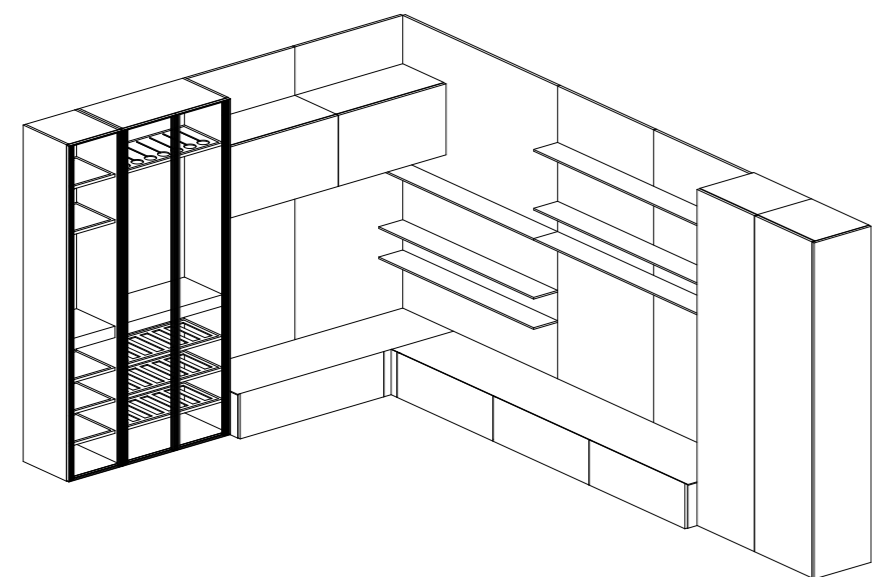
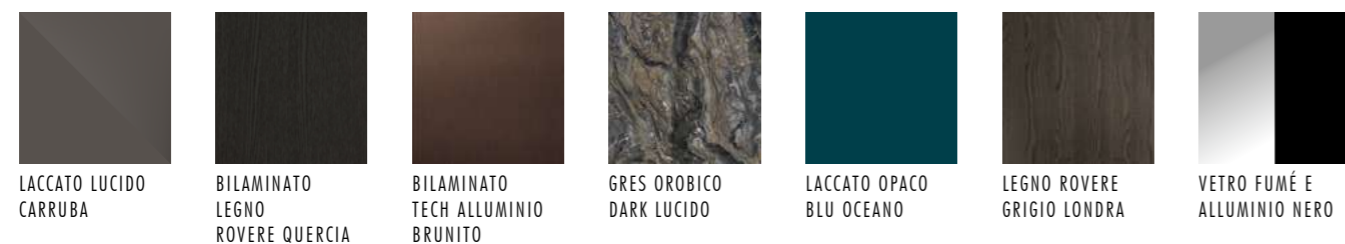

PARETE LIVING LIVING WALL

L 486X319 H 235,5 P 47,5/55

BLUNA 30° LACCATO LUCIDO CARRUBA
 BLUNA BILAMINATO LEGNO ROVERE QUERCIA
 VETRINE REFLEX TELAIO NERO E VETRO FUMÉ,
 STRUTTURA BILAMINATO LEGNO ROVERE QUERCIA
 SCHIENALE GRES OROBICO DARK LUCIDO E TECH ALLUMINIO BRUNITO

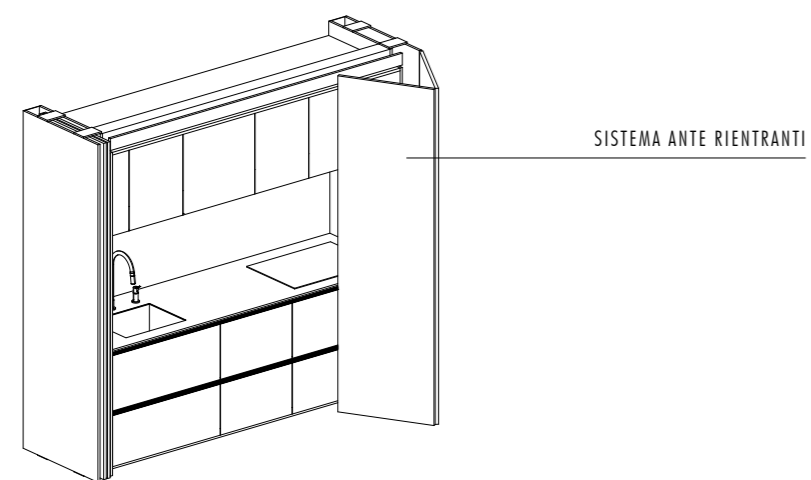

PARETE CUCINA KITCHEN WALL

L 270 CM H 235,5 P 80

BLUNA BILAMINATO LEGNO ROVERE QUERCIA
 BLUNA TECH ALLUMINIO BRUNITO
 TOP GRES OROBICO DARK LUCIDO

BLUNA LACCATO LUCIDO

**SCHEDA TECNICA DATA SHEET
 FICHE TECHNIQUE FICHA DE DATOS**



TAVOLO MOOR 01 TABLE

L. 150 H. 76 P. 150

TOP GRES OROBICO DARK LUCIDO
 STRUTTURA LEGNO FRASSINO CARBONE E
 SOTTOPIANA LACCATO OPACO NERO TRAFFICO

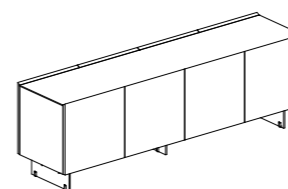

MADIA SIDEBOARD

L. 200 H. 66 P. 50

BLUNA 30° LACCATO LUCIDO CARRUBA
 STRUTTURA INTERNA LACCATO OPACO BLU OCEANO
 TOP GRES OROBICO DARK LUCIDO
 BASAMENTO CUT METALLO BRONZO

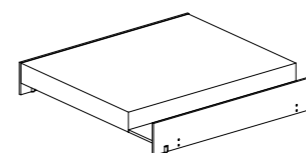

TAVOLO DA CAFFÈ COFFEE TABLE

L. 100 H. 16 P. 100

TOP ALTO LEGNO ROVERE GRIGIO LONDRA
 TOP SOTTILE GRES OROBICO DARK LUCIDO
 STRUTTURA METALLO NERO OPACO

44

45

MANTIS + LAB



MANTIS + LAB

47

Un ambiente che celebra la tecnologia dei materiali, da un lato Mantis con ante spessore 12 mm in legno spina di pesce e cuore in alveolare di alluminio per estendere i frontali oltre i limiti ordinari mentre dall'altro Lab con ante in telaio di alluminio capaci di sostenere lastre di gres nella parte frontale. La parete living è connotata da 3 elementi fondamentali, a sinistra le colonne alte interrotte dalle vetrine reflex, a destra una linea sottilissima rappresentata dalle basi in gres ed i moduli folding, mentre in alto i pensili in alluminio riflettente in total look con i riflessi del gres finitura pietra. A seguire si snoda la zona pranzo con tavolo e due madie alte ad uso bar. La continuità degli ambienti diventa logica, mentre l'espressione della tecnologia arriva persino ad alleggerire il metallo, rendendo l'insieme degli elementi più raffinato e al contempo più forte e persistente. An environment that celebrates the technology of the materials, on one side Mantis with 12 mm thick door in wood plug and heart in aluminum alveolar to extend the fronts beyond the ordinary limits while on the other lab with doors in aluminum frame capable of support stoneware plates in the front. The Living wall is connoted by 3 fundamental elements, on the left the high columns interrupted by the SLR showcases, to the right a very thin line represented by the bases in stoneware and folding modules, while in high the reflective aluminum wall units in total look with the reflections of the Stone finish stoneware. Following is the dining area with table and two high machines for bar use. The continuity of the rooms becomes logical, while the expression of technology even comes to lighten the metal, making the whole elements more refined and at the same time stronger and persistent.





50

51



DETTAGLIO PARETE
LIVING IN LAB GRES
FINITURA GRIS DU
GENT OPACO E TELAIO
CHAMPAGNE, MODULI
FOLDING E PENSILI
TECH ALLUMINIO
CHAMPAGNE,
COLONNE MANTIS
LEGNO SPINA DI
PESCE ROVERE MAGMA
E VETRINE REFLEX
TELAIO CHAMPAGNE E
VETRO FUMÉ.

LIVING WALL DETAIL
IN LAB GRES GRIS DU
GENT MATT FINISH AND
CHAMPAGNE FRAME,
FOLDING MODULES
TECH ALUMINUM
CHAMPAGNE,
MANTIS COLUMNS
HERRINGBONE
WOOD ROVERE
MAGMA FINISH AND
REFLEX GLASS UNIT
CHAMPAGNE FRAME
AND FUMÉ GLASS.

LIVING WALL DETAIL
IN LAB GRES GRIS DU
GENT MATT FINISH AND
CHAMPAGNE FRAME,
FOLDING MODULES
TECH ALUMINUM
CHAMPAGNE,
MANTIS COLUMNS
HERRINGBONE
WOOD ROVERE
MAGMA FINISH AND
REFLEX GLASS UNIT
CHAMPAGNE FRAME
AND FUMÉ GLASS.

LIVING WALL DETAIL
IN LAB GRES GRIS DU
GENT MATT FINISH AND
CHAMPAGNE FRAME,
FOLDING MODULES
TECH ALUMINUM
CHAMPAGNE,
MANTIS COLUMNS
HERRINGBONE
WOOD ROVERE
MAGMA FINISH AND
REFLEX GLASS UNIT
CHAMPAGNE FRAME
AND FUMÉ GLASS.



DETTAGLIO MADIA
ALTA IN LEGNO
ROVERE CARBONE,
TOP IN GRES FINITURA
GRIS DU GENT
OPACO E STRUTTURA
LACCATO OPACO
VERDE PASTELLO.
TAVOLO AFFIORO 02
CON STRUTTURA IN
FRASSINO CARBONE E
PIANO IN GRES GRIS
DU GENT OPACO.

DETAIL OF SIDEBOARD
IN WOOD ROVERE
CARBONE FINISH,
TOP IN GRES GRIS DU
GENT MATT FINISH
AND STRUCTURE MATT
LACQUERED VERDE
PASTELLO FINISH.
AFFIORO 02 TABLE WITH
STRUCTURE FRASSINO
CARBONE FINISH AND
TOP IN GRES GRIS DU
GENT MATT FINISH.

DETAIL OF SIDEBOARD
IN WOOD ROVERE
CARBONE FINISH,
TOP IN GRES GRIS DU
GENT MATT FINISH
AND STRUCTURE MATT
LACQUERED VERDE
PASTELLO FINISH.
AFFIORO 02 TABLE WITH
STRUCTURE FRASSINO
CARBONE FINISH AND
TOP IN GRES GRIS DU
GENT MATT FINISH.

DETAIL OF SIDEBOARD
IN WOOD ROVERE
CARBONE FINISH,
TOP IN GRES GRIS DU
GENT MATT FINISH
AND STRUCTURE MATT
LACQUERED VERDE
PASTELLO FINISH.
AFFIORO 02 TABLE WITH
STRUCTURE FRASSINO
CARBONE FINISH AND
TOP IN GRES GRIS DU
GENT MATT FINISH.



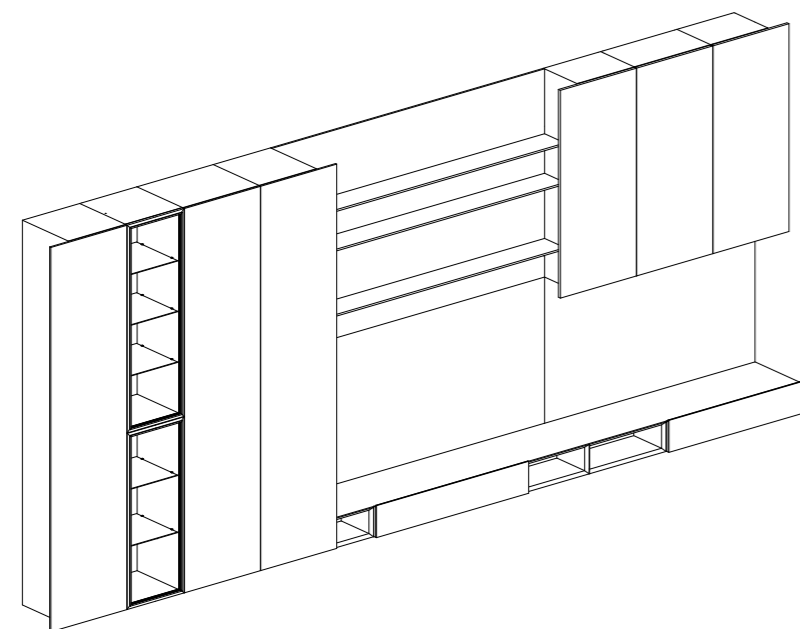
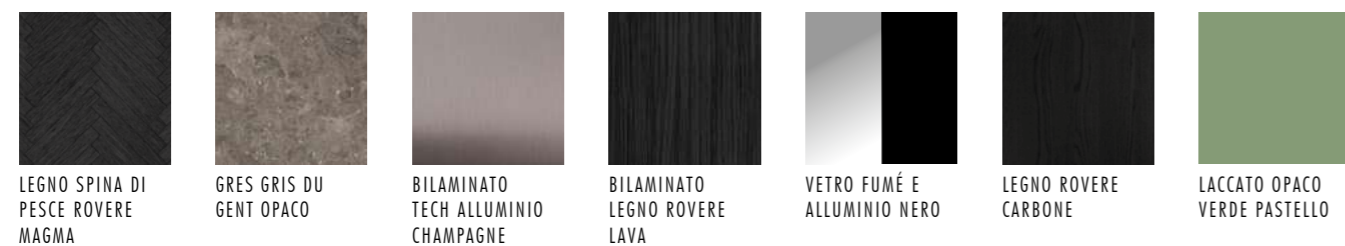

PARETE LIVING LIVING WALL

L 590 H 255 P 47,5

MANTIS LEGNO SPINA DI PESCE ROVERE MAGMA
LAB GRES GRIS DU GENT OPACO CON TELAIO CHAMPAGNE
 BLUNA TECH ALLUMINIO CHAMPAGNE
 VETRINE REFLEX TELAIO CHAMPAGNE E VETRO FUMÉ, STRUTTURA BILAMINATO LEGNO ROVERE LAVA
 BOISERIE LEAF E OPEN SPACE FOLDING TECH ALLUMINIO CHAMPAGNE
 SCHIENALE GRES GRIS DU GENT OPACO

MANTIS + LAB

SCHEDA TECNICA DATA SHEET
FICHE TECHNIQUE FICHA DE DATOS

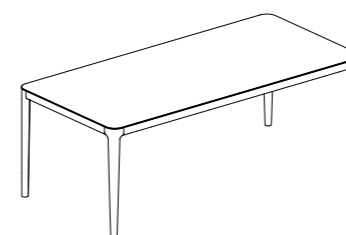

TAVOLO FIRENZE 02 TABLE

L. 210 H. 76 P. 100

TOP GRES GRIS DU GENT OPACO
 STRUTTURA LEGNO FRASSINO CARBONE

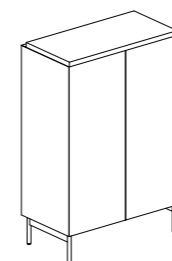

MADIA SIDEBOARD

L. 94,4 H. 143 P. 50

BLUNA 30° LEGNO ROVERE CARBONE
 STRUTTURA INTERNA LACCATO OPACO VERDE PASTELLO
 TOP GRES GRIS DU GENT OPACO
 BASAMENTO ROUND METALLO NERO OPACO

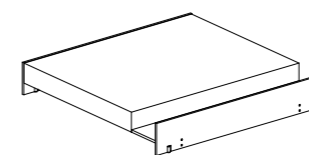

TAVOLO DA CAFFÈ COFFEE TABLE

L. 100 H. 16 P. 100

TOP ALTO LEGNO ROVERE CARBONE
 TOP SOTTILE GRES GRIS DU GENT OPACO
 STRUTTURA METALLO CHAMPAGNE

58

59

REGULA + BLUNA



REGULA + BLUNA

61

Un ambiente che ruota attorno al progetto Regula, nato nell'anno 1998 e che si basa sul concetto di sospendere i mobili su piedini in alluminio. Lo spazio si snoda tra una zona pranzo con tavolo e madie alte ed una zona living costituita da una parete dove le basi basse si intersecano con una parete tv dove i giochi di luce dei pannelli di profondità diverse danno risalto alla boiserie con ripiani. Il nuovo progetto casa consente di osare sempre di più. L'audacia di cambiare può custodire il seme di quella genialità che fa intuire la direzione prima di altri, dell'attimo in cui si capisce di aver realizzato qualcosa che si credeva impossibile. An environment that revolves around the Regula project, born in the year 1998 and which is based on the concept of suspending furniture on aluminum feet. The space winds between a dining area with a table and high mothers and a living area consisting of a wall where the low bases intersect with a TV wall where the games of different depth panels emphasize the boiserie with shelves. The new home project allows you to dare more and more. The boldness of changing can guard the seed of that genius that makes the management before others, of the moment in which you understand that you have realized something that was believed impossible.





DETTAGLIO PARETE LIVING CON BASI IN FENIX ROSSO JAIPUR, PIANO IN LEGNO ROVERE CARBONE, BOISERIE IN LEGNO ROVERE CARBONE E PANNELLI SCHIENALI IN BILAMINATO MATERICO PIASENTINA.

DETAIL OF LIVING WALL WITH LOWER BASES IN ROSSO JAIPUR FENIX, TOP IN ROVERE CARBONE WOOD, BOISERIE IN ROVERE CARBONE WOOD AND BACK PANELS IN MATERICO BILAMINATE PIASENTINA.

DETAIL OF LIVING WALL WITH LOWER BASES IN ROSSO JAIPUR FENIX, TOP IN ROVERE CARBONE WOOD, BOISERIE IN ROVERE CARBONE WOOD AND BACK PANELS IN MATERICO BILAMINATE PIASENTINA.

DETAIL OF LIVING WALL WITH LOWER BASES IN ROSSO JAIPUR FENIX, TOP IN ROVERE CARBONE WOOD, BOISERIE IN ROVERE CARBONE WOOD AND BACK PANELS IN MATERICO BILAMINATE PIASENTINA.





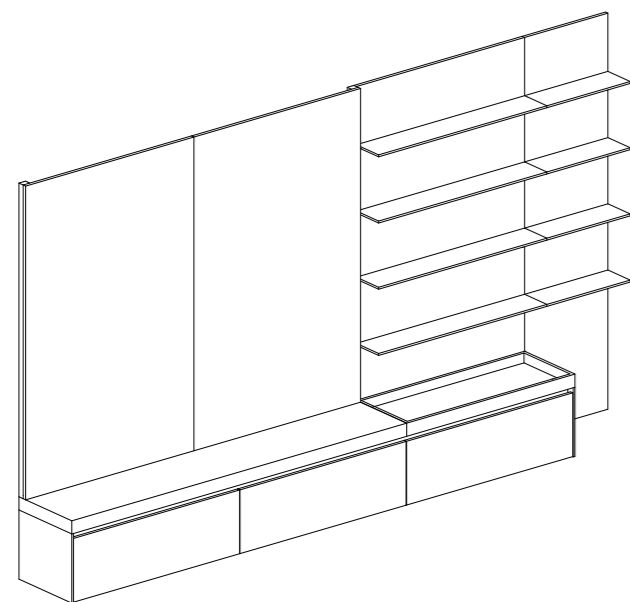
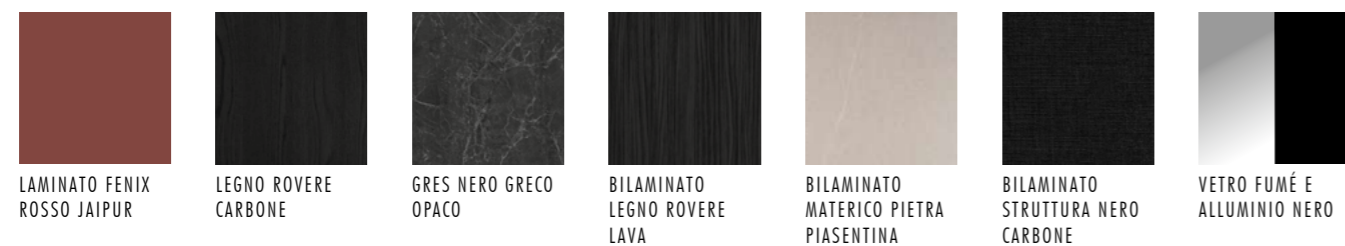

PARETE LIVING LIVING WALL
 L 420 H 240 P 47,5
 BLUNA LAMINATO FENIX ROSSO JAIPUR
 TOP LEGNO ROVERE CARBONE CON VASCA INTEGRATA
 BOISERIE LEAF LEGNO ROVERE CARBONE
 SCHIENALE BILAMINATO MATERICO PIETRA PIASENTINA

REGULA + BLUNA

SCHEDA TECNICA DATA SHEET
 FICHE TECHNIQUE FICHA DE DATOS

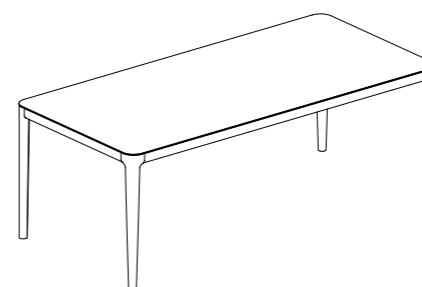

TAVOLO FIRENZE 02 TABLE
 L. 210 H. 76 P. 100
 TOP GRES NERO GRECO OPACO
 STRUTTURA LEGNO FRASSINO CARBONE

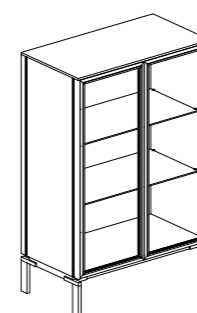

MADIA REGULA SIDEBBOARD
 L. 92,4 H. 140 P. 47,5
 VETRINE REFLEX CON TELAIO NERO E VETRO FUMÉ
 STRUTTURA INTERNA BILAMINATO LEGNO ROVERE LAVA
 TOP E FIANCHI LEGNO ROVERE CARBONE
 BASAMENTO REGULA ALLUMINIO NERO OPACO

70

71

BLUNA METAL 4.0



BLUNA METAL 4.0

73

Un ambiente che mette in relazione gli spazi della casa, eliminando la separazione tra zona soggiorno e cucina. Grazie all'uso delle colonne pilastri, elementi verticali contenitivi e funzionali, ogni ambiente si sviluppa in aree delimitate ma aperte, simili a spazi teatrali, di ampio respiro. Due materiali innovativi caratterizzano la composizione: da una parte, il laccato metal 4.0 che riveste le basi sospese ed esalta la modernità dell'insieme, dall'altra le vetrine illuminate sullo schienale che creano uno spettacolare effetto di rilievo. Librerie ancorate tra terra e soffitto caratterizzano l'ambiente e vanno a dividere la zona pranzo dall'ambiente circostante. An environment that connects the spaces of the house, eliminating the separation between the living area and the kitchen. Thanks to the use of pillar columns, vertical containing and functional elements, each room is developed in delimited but open areas, similar to theatrical spaces, with a broad scope. Two innovative materials characterize the composition: on the one hand, the 4.0 metal lacquer that covers the suspended bases and enhances the modernity of the whole, on the other hand the illuminated display cabinets on the back create a spectacular relief effect. Bookcases anchored between the ground and the ceiling characterize the environment and divide the dining area from the surrounding environment.





DETTAGLIO PARETE LIVING CON BASI SOSPESE IN FINITURA BLUNA LACCATO METAL 4.0 BRONZO CON PROFILO GAP IN ALLUMINIO NERO, PENSILI CON ANTE VETRO MILES CON TELAIO NERO E VETRO FUMÉ, SCHIENALI IN LEGNO FINITURA ROVERE CARBONE.

DETAIL OF LIVING WALL WITH BASE UNITS BLUNA 4.0 METAL LACQUERED BRONZE FINISH WITH BLACK ALUMINUM GAP PROFILE, WALL UNITS WITH MILES GLASS DOORS MADE IN BLACK ALUMINUM FRAME AND FUMÉ GLASS, BACK PANELS ARE IN WOOD ROVERE CARBONE FINISH.

DETAIL MUR LIVING AVEC MEUBLES BAS SUSPENDUS EN FINITION BLUNA LAQUE METAL 4.0 BRONZE AVEC PROFIL GAP EN ALUMINIUM NOIR, MEUBLES HAUTS AVEC FAÇADES EN VERRE MILES AVEC CADRE NOIR ET VERRE FUMÉ, DOS EN BOIS FINITION ROVERE CARBONE.

DETALLE PARED LIVING CON BAJOS SUSPENDIDOS LACADO METAL 4.0 ACABADO BRONZO CON PERFIL GAP EN ALUMINIO NEGRO, ALTOS CON PUERTAS DE VIDRIO MILES CON MARCO DE ALUMINIO NEGRO Y VIDRIO FUMÉ, ESPALDA EN MADERA ACABADO ROVERE CARBONE.

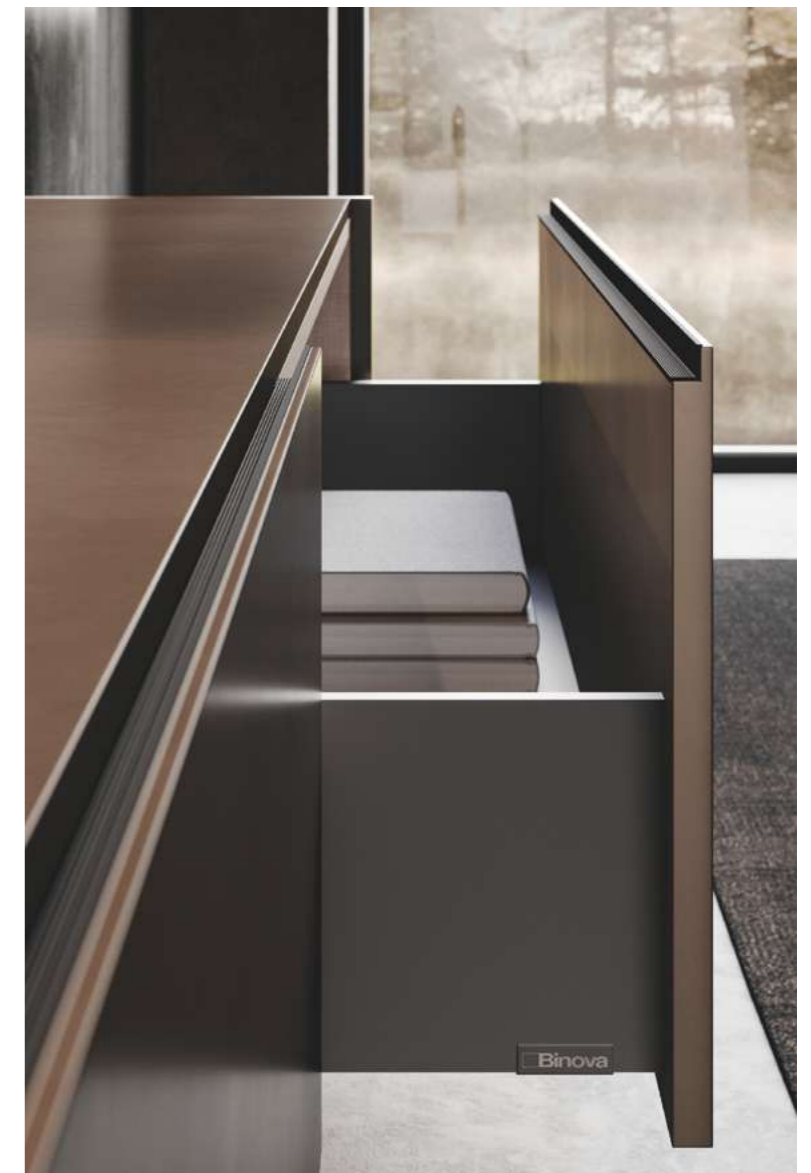



DETTAGLIO MADIA
CON ANTE MILES
IN VETRO FUME' E
TELAIO IN FINITURA
ALLUMINIO NERO.
STRUTTURA INTERNA
IN FINITURA
BILAMINATO ROVERE
LAVA CON SCHIENA
IN FINITURA GREY
FABRIC. PIANO
IN GRES OPACO
FINITURA MARBLE
GREY.

DETAIL OF
SIDEBOARD WITH
MILES DOORS MADE
IN FUME' GLASS AND
BLACK ALUMINIUM
FRAME. INTERNAL
STRUCTURE IS IN
WOOD BILAMINATE
ROVERE LAVA AND
BACK PANEL IS IN
GREY FABRIC FINISH.
PLANE IN MATT
GRES MARBLE GREY
FINISH.

DETAIL BUFFET
AVEC FAÇADES
MILES EN VERRE
FUME ET CADRE EN
FINITION ALUMINIUM
NOIR. STRUCTURE
INTERNE EN FINITION
BILAMINE ROVERE
LAVA AVEC DOS
EN FINITION GREY
FABRIC. PLAN DE
TRAVAIL EN GRÈS MAT
FINITION MARBLE
GREY.

DETALLE DEL APARADOR
CON PUERTAS DE
MILLAS HECHAS EN
VIDRIO DE FUMA Y
MARCO DE ALUMINIO
NEGRO. LA ESTRUCTURA
INTERNA ESTÁ EN
MADERA BILAMINADA
ROVERE LAVA Y EL
PANEL POSTERIOR
ESTÁ EN ACABADO DE
TELA GRIS. PLANO EN
ACABADO GRIS MÁRMOL
GRIS MATE.



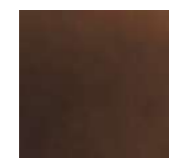

LACCATO METAL
4.0 BRONZO

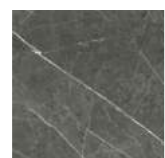

GRES MARBLE GREY
OPACO



BILAMINATO
LEGNO ROVERE
LAVA



LACCATO OPACO
NERO TRAFFICO

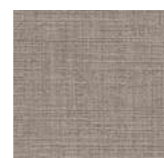

BILAMINATO
STRUTTURA NERO
CARBONE



VETRO FUMÈ E
ALLUMINIO NERO

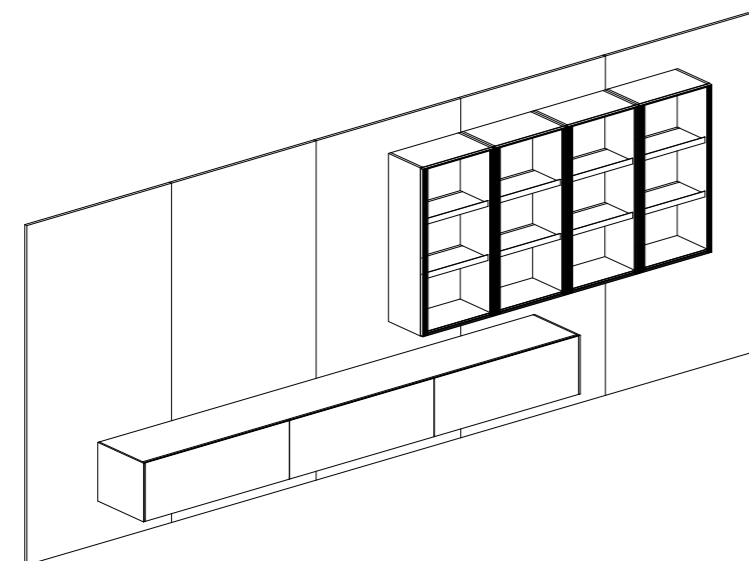

PARETE LIVING LIVING WALL

L 480 H 235,5 P 47,5/35,5

BLUNA LACCATO METAL 4.0 BRONZO CON MANIGLIA GAP NERA
VETRINE MILES TELAIO NERO E VETRO FUMÈ, STRUTTURA
BILAMINATO LEGNO ROVERE LAVA
SCHIENALE BILAMINATO LEGNO ROVERE LAVA

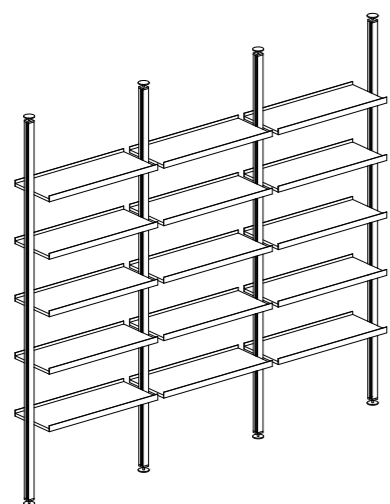

LIBRERIA PIVOT LIBRARY

L 290 CM H 270 P 35

RIPIANI BILAMINATO LEGNO ROVERE LAVA
PALI ALLUMINIO NERO OPACO

BLUNA METAL 4.0

SCHEDA TECNICA DATA SHEET
FICHE TECHNIQUE FICHA DE DATOS

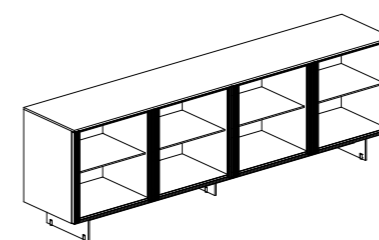

MADIA SIDEBORD

L. 240 H. 75 P. 47,5

VETRINE MILES TELAIO NERO E VETRO FUMÈ, STRUTTURA
BILAMINATO LEGNO ROVERE LAVA
TOP GRES MARBLE GREY OPACO
BASAMENTO CUT METALLO NERO OPACO

84

85

AVOLA GRES



AVOLA GRES

87

Un atto di grande libertà: quella del design minimalista che apre alla percezione di un'essenza marmorea che corre lungo i profili e le venature, segni precisi che diventano traccia comune e viva nel contrasto del chiaroscuro e nell'equilibrio costante tra l'estetica d'insieme e il punto del dettaglio. L'espansione di movimento diventa totale grazie al telaio in alluminio, che accoglie comodamente il pannello centrale ed al contempo consente la presa su tutti i lati. La parete living è costituita da contenitori sospesi Avola in finitura gres rigato mentre sulla parte superiore si snoda un piano sospeso in legno al quale viene associato un pensile metrico dello stesso materiale. La madia ripercorre le stesse finiture marmoree e fa da sfondo alla zona pranzo con vetrine alte e tavolo in legno. This is an expression of real liberty: the minimalist design is free to run with its vivid essence along contours and grain, sharp lines that become a common sign, living in the light and shade, balancing the global aesthetics and the slightest particulars. A model that is expansion: thanks to the aluminum frame, which comfortably allow space for the central panel and at the same time allows opening on every side. The living wall is made up of Avola suspended containers in a striped gres finish, while on the upper part there is a suspended wooden top to which a metric wall unit of the same material is associated. The sideboard traces the same marble finishes and acts as a background to the dining area with tall display cabinets and wooden table.





DETTAGLIO LIVING
CON ANTE TELAIO
IN FINITURA
ALLUMINIO NERO E
PANNELLO CENTRALE
IN FINITURA GRES
INSIDE PIETRA
PIASENTINA GRIGIA
FIAMMATA, TOP E
PENSILE METRICO IN
FINITURA LEGNO NOCE
CANALETTO, BOISERIE
LEAF IN FINITURA
LACCATO OPACO
GRIGIO ANTRACITE.

DETAIL OF LIVING
AREA WITH BLACK
ALUMINIUM FRAME
DOORS AND CENTRAL
PANEL INSIDE GRES
PIETRA PIASENTINA
FIAMMATA FINISH,
TOP AND METRIC
WALL UNIT IS IN
WOOD CANALETTO
WALNUT FINISH,
BOISERIE LEAF IS IN
MATT LACQUERED
GRIGIO ANTRACITE
FINISH.

DETAIL LIVING
AVEC PORTES AVEC
CADRE EN FINITION
ALUMINIUM NOIR ET
Panneau central
en finition GRES
INSIDE PIETRA
PIASENTINA GRIGIA
FIAMMATA, PLAN ET
MEUBLE METRIQUE EN
FINITION BOIS NOCE
CANALETTO, BOISERIE
LEAF EN FINITION
LAQUE MAT GRIGIO
ANTRACITE.

DETALLE PARED LIVING
CON PUERTAS DE
MARCO EN ACABADO
ALUMINIO NERO Y
PANEL CENTRAL EN
ACABADO GRES INSIDE
PIEDRA PIASENTINA
GRIS LLAMA ,
ENCIMERA Y MUEBLE
MÉTRICO ENCHAPADO
DE MADERA ACABADO
NOCE CANALETTO,
BOISERIE LEAF LACA
MATE ACABADO GRIGIO
ANTRACITE.





92

93



DETTAGLIO COLONNE
CON ANTE REFLEX IN
VETRO FUME' E TELAIO
IN FINITURA ALLUMINIO
NERO OPACO.

DETAIL OF COLUMN
WITH REFLEX DOORS
MADE IN FUME'
GLASS AND BLACK
ALUMINUM FRAME.

DETAIL COLONNE
AVEC PORTES REFLEX
EN VERRE FUME ET
CADRE EN FINITION
ALUMINIUM NOIR MAT.

DETALLES DE COLUMNAS
CON PUERTAS REFLEX
EN VIDRIO FUME' Y
MARCO EN ACABADO DE
ALUMINIO NERO MATE.

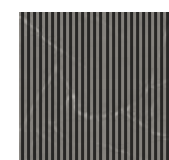

GRES INSIDE
PIETRA PIASENTINA
GRIGIO FIAMMATO
RIGATO

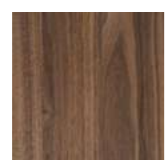

LEGNO SPECIALE
NOCE CANALETTO



LACCATO OPACO
GRIGIO ANTRACITE

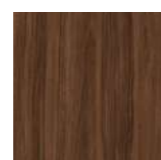

BILAMINATO
LEGNO NOCE
AMERICANO

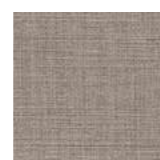

BILAMINATO
STRUTTURA GREY
FABRIC



VETRO FUMÉ E
ALLUMINIO NERO

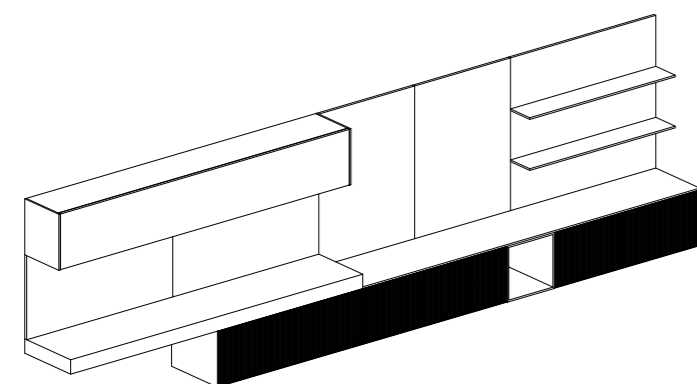

PARETE LIVING LIVING WALL

L 522 H 147 P 47,5

AVOLA GRES INSIDE PIETRA PIASENTINA GRIGIO
FIAMMATO RIGATO CON TELAIO NERO OPACO
BOISERIE LEAF LACCATO OPACO GRIGIO ANTRACITE
BLUNA LEGNO SPECIALE NOCE CANALETTO

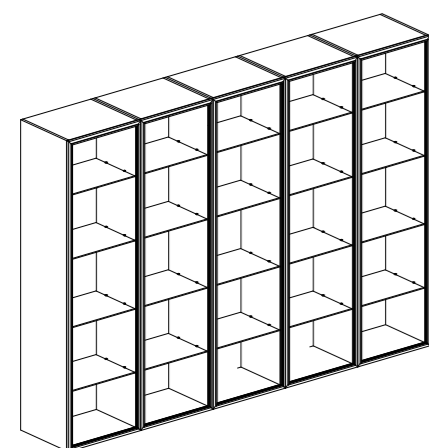

VETRINE REFLEX GLASS UNITS

L 300 CM H 216 P 47,5

VETRINE REFLEX CON TELAIO NERO E VETRO FUMÉ
STRUTTURA INTERNA BILAMINATO LEGNO NOCE AMERICANO

AVOLA GRES

**SCHEDA TECNICA DATA SHEET
FICHE TECHNIQUE FICHA DE DATOS**

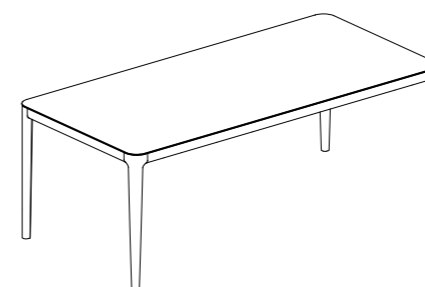

TAVOLO FIRENZE 02 TABLE

L. 210 H. 76 P. 100

TOP GRES PIETRA PIASENTINA GRIGIO FIAMMATO
STRUTTURA LEGNO FRASSINO MIELE

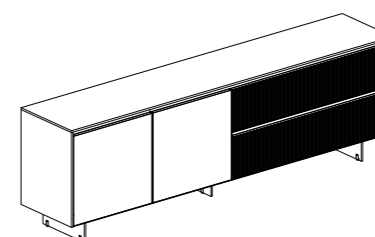

MADIA SIDEBOARD

L. 242,4 H. 79 P. 47,5

AVOLA GRES INSIDE PIETRA PIASENTINA GRIGIO FIAMMATO
RIGATO CON TELAIO NERO OPACO
TOP E FIANCHI LEGNO SPECIALE NOCE CANALETTO
TOP GRES GRES INSIDE PIETRA PIASENTINA GRIGIO FIAMMATO
BASAMENTO CUT METALLO NERO OPACO

96

97

MANTIS + BLUNA



MANTIS + BLUNA

99

Mantis è il momento in cui il progetto si sostituisce all'elemento architettonico, in cui gli arredi che una volta separavano ora creano un continuum: la fluidità degli ambienti diventa logica, mentre l'espressione della tecnologia arriva persino ad alleggerire il metallo, rendendo l'insieme degli elementi più raffinato e al contempo più forte e persistente. Andare oltre la possibilità di uno spazio così come ci è dato non è privilegio: è talento. Scomporre lo sguardo significa creare pareti per tracciare uno spazio di vita che sia unico eppure quotidiano. Significa concepire un sistema di linee pure talmente personale in cui riconoscersi da ogni punto di vista. Mantis è un progetto di architettura integrata che porta ai massimi livelli l'evoluzione di tecnologia e spazio, laddove quest'ultimo è espanso in termini di uso e di tempo. L'unione di concetti polari è una cifra costante che si proietta sulla leggerezza degli altissimi frontali resa possibile da ante in alluminio di spessore 12 millimetri realizzate in alveolare di alluminio e rivestite con differenti materiali. Mantis is a design, taking place of the architectural elements: what once used to separate now is a connection, and the continuity of the spaces becomes a logic consequence. We enhance all the many possibilities that advanced technology delivers, like lightening the strong metal frame to obtain a thinner and persistent product. Improving the resources of a given space is not a chance: it is a real talent. Syllabizing the glance means creating new walls that mark a unique space made out of the essence of our daily life. It is the concept of a whole living system expressed with such pure and universal lines, so personal that it will clearly tell something about us anywhere our gaze will turn. Mantis is an incorporated architecture project representing the evolution of technology and space concepts, as space itself is an extension of time and using capability. The union of polar concepts is the key to read the tall frontals we have created thanks to the 12 mm thick aluminium doors.





DETTAGLIO LIVING
CON ANTE MANTIS IN
FINITURA LACCATO
OPACO BEIGE KENIA,
PIANO IN GRES TAJ
MAHAL OPACO E
SCHIENALE IN LEGNO
ROVERE CARBONE.

DETAIL OF LIVING AREA
WITH MANTIS DOORS
MATT LACQUERED BEIGE
KENIA, TOP IN MATT
GRES TAJ MAHAL FINISH
AND BACK PANEL IN
WOOD ROVERE CARBONE
FINISH.

DETAIL LIVING AVEC
PORTES MANTIS EN
FINITION LAQUE
MAT BEIGE KENIA,
PLAN EN GRES TAJ
MAHAL MAT ET DOS
EN FINITION BOIS
ROVERE CARBONE.

DETALLE PARED LIVING
CON PUERTAS MANTIS EN
ACABADO LACADO BEIGE
KENIA MATE, ENCIMERA
EN GRES ACABADO TAJ
MAHAL MATE Y ESPALDA
EN MADERA ROVERE
CARBONE.

102

103





104

105

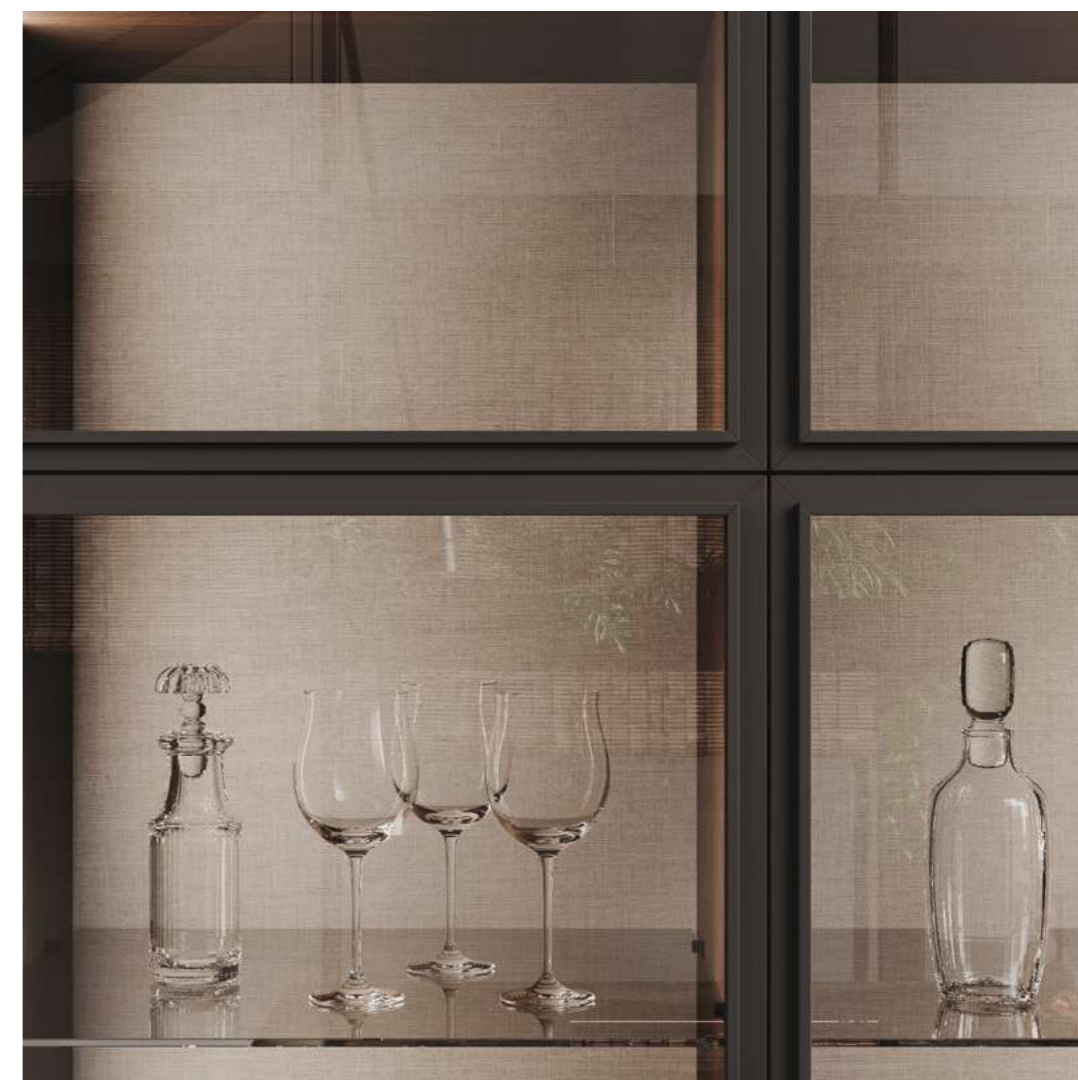

DETTAGLIO COLONNE
CON ANTE REFLEX
IN VETRO FUME' E
TELAIO IN FINITURA
ALLUMINIO NERO.
STRUTTURA INTERNA
IN FINITURA
BILAMINATO NOCE
MONZA CON SCHIENA
IN FINITURA GREY
FABRIC.

DETAIL OF COLUMNS
WITH REFLEX
DOORS MADE IN
FUME' GLASS AND
BLACK ALUMINUM
FRAME. INTERNAL
STRUCTURE IS IN
WOOD BILAMINATE
NOCE MONZA AND
BACK PANEL IS IN
GREY FABRIC FINISH.

DETAIL COLONNES
AVEC PORTES
REFLEX EN VERRE
FUME ET CADRE EN
FINITION ALUMINIUM
NOIR. STRUCTURE
INTERNE EN FINITION
BILAMINE NOCE
MONZA AVEC DOS
EN FINITION GREY
FABRIC.

DETALLES DE COLUMNAS
CON PUERTAS REFLEX
EN VIDRIO FUME' Y
MARCO EN ACABADO DE
ALUMINIO NERO MATE.
ESTRUCTURA INTERNA
EN BILAMINADO DE
MADERA ACABADO NOCE
MONZA CON ESPALDA
EN ACABADO GREY
FABRIC.

DETTAGLIO MADIA
IN FINITURA
LACCATO LUCIDO
BEIGE KENIA ED
INSERTO IN FINITURA
LEGNO ROVERE
TERMOTRATTATO.
BASAMENTO VERNICIATO
NERO OPACO.

DETAIL OF SIDEBOARDS
IN GLOSSY LACQUERED
BEIGE KENIA FINISH
AND INSERT IN
OAK WOOD ROVERE
TERMOTRATTATO
FINISH. LOWER
STRUCTURE MATT
BLACK FINISH.

DETAIL BUFFET EN
FINITION LAQUE
BRILLANT BEIGE
KENIA ET INSERTS
EN FINITION
BOIS ROVERE
TERMOTRATTATO,
BASE VERNIE EN
FINITION NOIR MAT.

DETALLE APARADOR
EN LACADO BRILLANTE
ACABADO BEIGE
KENIA E INSERTE
EN ENCHAPADO DE
MADERA ROVERE
TERMOTRATADO.
BASE PINTADA NEGRA
MATE.

106

107



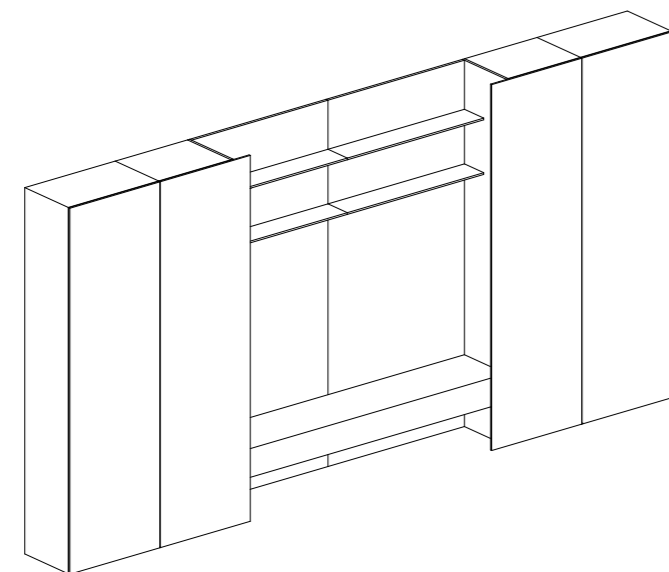

PARETE LIVING LIVING WALL

L 500 H 255 P 47,5

MANTIS LACCATO OPACO BEIGE KENIA
BOISERIE LEAF LEGNO ROVERE CARBONE CON MENSOLE
LACCATO OPACO NERO TRAFFICO
PIANO SOSPESO GRES TAJ MAHAL OPACO

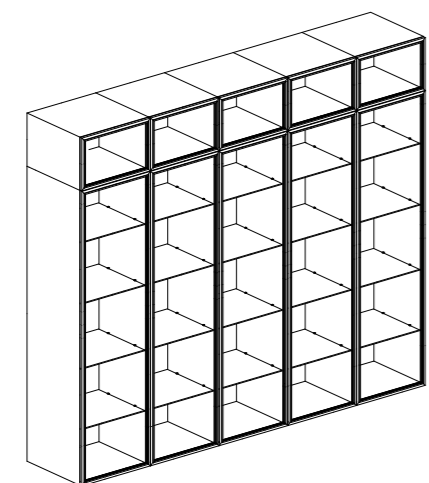

VETRINE REFLEX GLASS UNITS

L 300 CM H 255 P 47,5

VETRINE REFLEX CON TELAIO NERO E VETRO FUMÈ
STRUTTURA INTERNA BILAMINATO LEGNO NOCE MONZA

MANTIS + BLUNA

SCHEDA TECNICA DATA SHEET
FICHE TECHNIQUE FICHA DE DATOS



TAVOLO MOOR 01 TABLE

L. 150 H. 76 P. 150

TOP GRES TAJ MAHAL OPACO
STRUTTURA LEGNO FRASSINO CARBONE E
SOTTOPIANA LACCATO OPACO NERO TRAFFICO

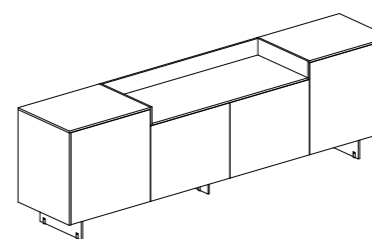

MADIA SIDEBOARD

L. 242,4 H. 76 P. 47,5

BLUNA LACCATO LUCIDO BEIGE KENIA
VASCA LEGNO ROVERE TERMOTRATTATO
BASAMENTO CUT METALLO NERO OPACO

110

111

REFLEX + VOGUE



REFLEX + VOGUE

113

Un grande spazio living caratterizzato da una parete divisa in due parti, una piena adibita ad accogliere la zona pranzo contenente un lungo camino ed un tavolo davanti ad esso e l'altra svuotata costituita da vetrine sospese in una boiserie di metallo che sovrastano un piano in legno poggiato a terra. Lo spazio è libero ed al contempo organizzato, i volumi si compensano a vicenda e fanno sì che ogni cosa possa essere riposta al proprio posto. Sul lato destro spicca la madia Vogue, progetto di punta della collezione, consiste in un gioco di pieni e vuoti dato dai frontali con maniglie ricavate all'interno del bordo verticale. E' caratterizzato oltremodo dalla speciale finitura a doghe sfalsate che esalta l'andamento scostante al ripetersi dei frontali di eguale misura. A large living space characterized by a wall divided into two parts, one full used to accommodate the dining area containing a long fireplace and a table in front of it and the other emptied consisting of a display cabinet suspended in a metal boiserie overlooking a wood resting on the ground. The space is free and at the same time organized, the volumes compensate each other and ensure that everything can be put back in its place. On the right side stands the Vogue sideboard, the collection's flagship project, consisting of a play of solids and voids given by the fronts with handles obtained inside the vertical edge. It is extremely characterized by the special staggered slot finish that enhances the unfriendly trend with the repetition of fronts of equal size.



DETTAGLIO MADIA
CON ANTE VOGUE
LEGNO IN FINITURA
ROVERE VESUVIO
DOGA SFALSATA E
TOP IN GRES INSIDE
FINITURA PIETRA
PIASENTINA GRIGIO
FIAMMATO.

DETAIL OF SIDEBOARD
WITH VOGUE DOORS
WOOD ROVERE
VESUVIO DOGA
SFALSATA FINISH,
WORKTOP INSIDE
GRES PIETRA
PIASENTINA GRIGIO
FIAMMATO FINISH.

DETAIL BUFFET AVEC
FAÇADES VOGUE BOIS
EN FINITION ROVERE
VESUVIO AVEC LATTES
IRREGULIERES ET
PLAN EN GRES INSIDE
FINITION PIETRA
PIASENTINA GRIGIO
FIAMMATO.

DETALLE APARADOR
CON PUERTAS
VOGUE MADERA EN
ACABADO DE ROVERE
VESUVIO CON LISTON
ESCALONADO Y
ENCIMERA EN GRES
INSIDE PIETRA
PIASENTINA LLAMA.

116

117





BLUNA + VOGUE

SCHEDA TECNICA DATA SHEET
FICHE TECHNIQUE FICHA DE DATOS

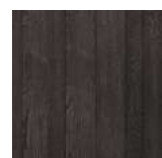

LEGNO SPECIALE
ROVERE VESUVIO
DOGA SFALSATA



GRES INSIDE
PIETRA PIASENTINA
GRIGIO FIAMMATO

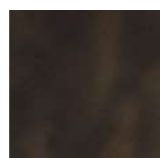

BILAMINATO
MATERICO
METALLO NUVOLA

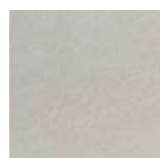

BILAMINATO
MATERICO BETON
ARGILLA

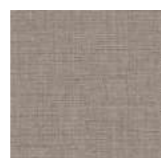

BILAMINATO
STRUTTURA GREY
FABRIC



VETRO FUMÉ E
ALLUMINIO NERO

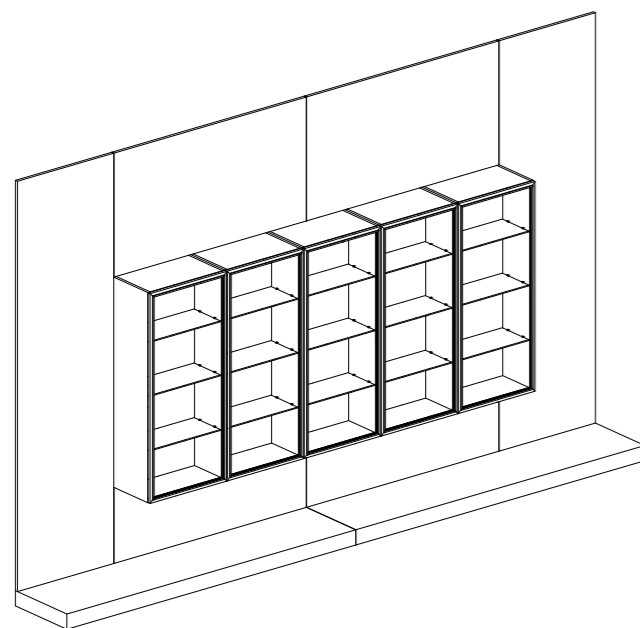

PARETE LIVING LIVING WALL

L 300 H 200 P 35,5

VETRINE REFLEX TELAIO NERO E VETRO FUMÉ, STRUTTURA BILAMINATO MATERICO BETON ARGILLA
PIANO FOLDING A TERRA LEGNO ROVERE VESUVIO DOGA SFALSATA
SCHIENALE BILAMINATO MATERICO BETON NUVOLA

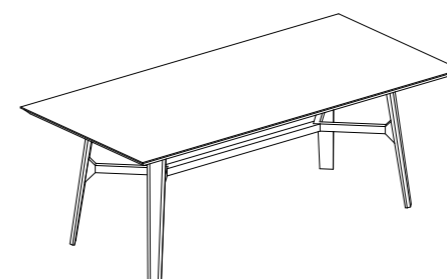

TAVOLO MOOR 02 TABLE

L. 200 H. 76 P. 100

TOP GRES PIETRA PIASENTINA GRIGIO FIAMMATO OPACO
STRUTTURA LEGNO FRASSINO CARBONE E SOTTOPIANA
LACCATO OPACO NERO TRAFFICO

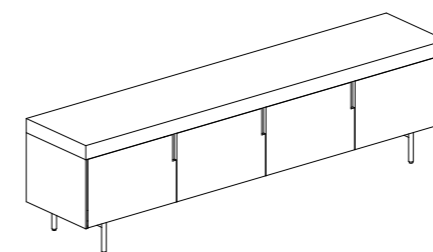

MADIA SIDEBOARD

L. 242,4 H. 69 P. 47,5

VOGUE LEGNO ROVERE VESUVIO DOGA SFALSATA
TOP GRES PIETRA PIASENTINA GRIGIO FIAMMATO OPACO
BASAMENTO ROUND METALLO NERO OPACO

122

123

BLUNA LEGNO



BLUNA LEGNO

125

L'idea di un ambiente conviviale è al centro di questo progetto, uno spazio attorno al quale vivere ogni momento in compagnia e dove nulla è celato ma tutto è visibile ed aperto alla condivisione. La parete living è caratterizzata da un alternarsi di piani sfalsati tra loro, a partire dal basso il piano in legno poggiato a terra crea uno speciale dinamismo arricchito ancor più dalle basi che richiamano la stessa finitura. Nella parte alta completano il gioco di volumi le vetrine illuminate e la boiserie con funzione di sostegno per la tv. Sul fondo spicca la zona pranzo nella quale delle colonne basse fanno quasi da partecipi commensali all'evento e corredano a pieno lo spazio grazie all'alternanza di pieni e vuoti data dall'alternanza di vetrine e boiserie. The idea of a convivial environment is at the center of this project, a space around which to live every moment in company and where nothing is hidden but everything is visible and open to sharing. The living wall is characterized by an alternation of staggered floors, starting from the bottom the wooden top resting on the ground creates a special dynamism enriched even more by the bases that recall the same finish. In the upper part, the play of volumes is completed by the illuminated windows and the boiserie with support function for the TV. At the back stands the dining area in which low columns almost act as diners at the event and fully complement the space thanks to the alternation of solids and voids given by the alternation of shop windows and wood paneling.





DETTAGLIO PARETE
LIVING CON BASI
SOSPESE IN FINITURA
BLUNA LEGNO
ROVERE GRIGIO
LONDRA, PENSILI
CON ANTE VETRO
REFLEX CON TELAIO
NERO E VETRO
FUMÈ, SCHIENALI
IN BILAMINATO
MATERICO FINITURA
PIETRA PIASENTINA.

DETAIL OF LIVING
WALL WITH BASE UNITS
BLUNA WOOD ROVERE
GRIGIO LONDRA FINISH
AND WALL UNITS
WITH REFLEX GLASS
DOORS MADE IN BLACK
ALUMINUM FRAME
AND FUMÈ GLASS,
BACK PANELS ARE IN
MATERIC BILAMINATE
PIETRA PIASENTINA
FINISH.

DETAIL LIVING
AVEC MEUBLES BAS
SUSPENDUS EN
FINITION BLUNA
BOIS ROVERE GRIGIO
LONDRA, MEUBLES
HAUTS EN VERRE
REFLEX AVEC CADRE
NOIR ET VERRE
FUMÉ, DOS EN
BILAMINE MATERICO
FINITION PIETRA
PIASENTINA.

DETALLE PARED
LIVING CON BAJOS
SUSPENDIDOS BLUNA
ENCHAPADO DE
MADERA ACABADO
ROVERE GRIGIO
LONDRA, ALTOS
EN VIDRIO RÉFLEX
MARCO NERO VIDRIO
FUMÉ', ESPALDA
EN BILAMINADO
MATERICO ACABADO
PIETRA PIASENTINA.

128

129



DETTAGLIO COLONNE
BASSE CON ANTE
BLUNA IN FINITURA
LEGNO ROVERE
GRIGIO LONDRA
E ANTE IN VETRO
REFLEX CON TELAIO
NERO E VETRO FUMÈ.

DETAIL OF LOWER
COLUMN IN BLUNA
WOOD ROVERE GRIGIO
LONDRA FINISH AND
REFLEX GLASS DOORS
MADE IN BLACK
ALUMINUM FRAME
AND FUMÈ GLASS.

DETAIL COLONNES
BASSES AVEC FAÇADES
BLUNA EN FINITION
BOIS ROVERE GRIGIO
LONDRA ET PORTES
EN VERRE REFLEX
AVEC CADRE NOIR ET
VERRE FUMÈ.

DETTALLES COLUMNAS
BAJAS CON PUERTAS
BLUNA ENCHAPADO DE
MADERA ACABADO ROVERE
GRIGIO LONDRA Y PUERTAS
EN VIDRIO REFLEX MARCO
EN ACABADO DE ALUMINIO
NERO MATE VIDRIO FUMÈ'.

130

131





BILAMINATO
MATERICO PIETRA
PIASENTINA

LEGNO ROVERE
GRIGIO LONDRA

GRES INSIDE
PIETRA PIASENTINA
TAUPE FIAMMATO

BILAMINATO
MATERICO BETON
NUVOLA

BILAMINATO
STRUTTURA NERO
CARBONE

VETRO FUMÉ E
ALLUMINIO NERO

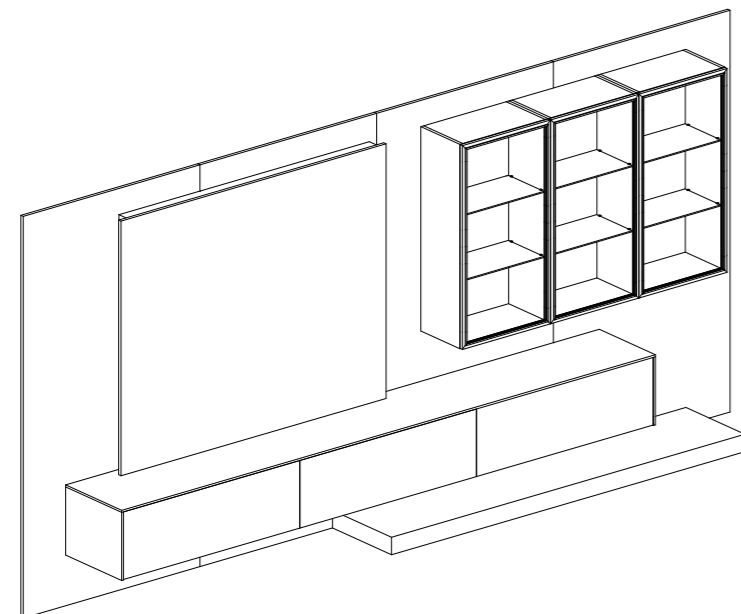

PARETE LIVING LIVING WALL

L 420 H 220 P 47,5

BLUNA LEGNO ROVERE GRIGIO LONDRA
VETRINE REFLEX TELAIO NERO E VETRO FUMÉ, STRUTTURA BILAMINATO MATERICO BETON NUVOLA
PIANO FOLDING A TERRA LEGNO ROVERE GRIGIO LONDRA
SCHIENALE BILAMINATO MATERICO PIETRA PIASENTINA

BLUNA LEGNO

SCHEDA TECNICA DATA SHEET
FICHE TECHNIQUE FICHA DE DATOS

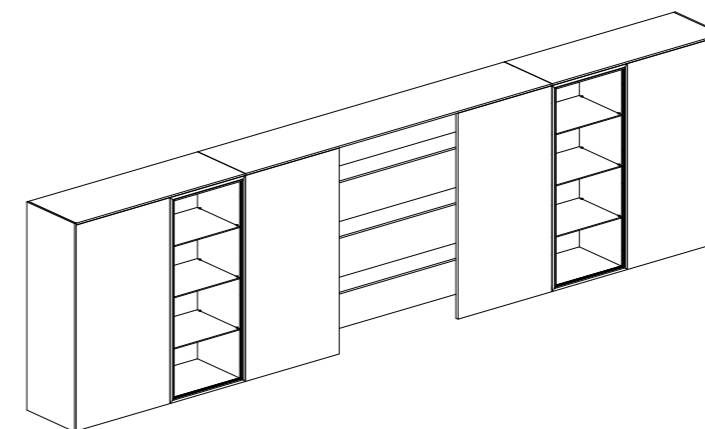

PARETE SALA DA PRANZO DINING ROOM WALL

L. 517 H. 138 P. 47,5

BLUNA LEGNO ROVERE GRIGIO LONDRA
VETRINE REFLEX TELAIO NERO OPACO E VETRO FUMÉ,
STRUTTURA INTERNA BILAMINATO MATERICO BETON NUVOLA
BOISERIE LEAF LEGNO ROVERE GRIGIO LONDRA

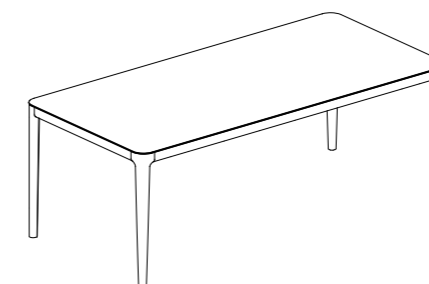

TAVOLO FIRENZE 02 TABLE

L. 210 H. 76 P. 100

TOP GRES INSIDE PIETRA PIASENTINA TAUPE FIAMMATO OPACO
STRUTTURA LEGNO FRASSINO MIELE

134

135

VOGUE + BLUNA



VOGUE + BLUNA

137

Gli spazi smettono di essere limitati da elementi strutturali per diventare zone aperte e di passaggio, in cui non esiste più una vera gerarchia operativa. Un progetto che definisce così lo spirito di una casa aperta che non teme di offrire prospettive informali, dove il mutare della percezione dello spazio è un valore e non una stravaganza. L'elemento principale attorno al quale ruota l'intero ambiente è la parete colonne ad L costituita da moduli di diverse profondità uniti assieme per costituire un'unica linea che congiunge la cucina al living e che utilizza i medesimi elementi, un "continuum" di contaminazioni tra forme e funzioni. Altra forte caratteristica delle colonne sono le aperture che alleggeriscono l'impatto del muro in legno ed al contempo consentono l'apertura dei frontali e dei meravigliosi coni di luce. La madia con ante Vogue è caratterizzata da tagli verticali che consentono l'apertura e dalla finitura laccata ossidata. La parete living ripercorre le stesse finiture della cucina ed è caratterizzata da una intersezione di volumi che consentono pieni e vuoti con vani folding incassati, mentre la madia è con ante Vogue e top in gres alto spessore. Spaces are no longer limited by structural elements becoming open areas where an operating hierarchy doesn't exist anymore. A project that defines the spirit of an open home that is no longer afraid of an informal outlook, where the perception of space is changing, no longer an extravagance. The main element around which the entire room revolves is the L-shaped column wall made up of modules of different depths joined together to form a single line that connects the kitchen from the living room and uses the same elements, a "continuum" of contamination between forms and functions. Another strong feature of the columns are the openings that lighten the impact of the wooden wall and at the same time allow the opening of the fronts and the wonderful light cones. The sideboard with Vogue doors is characterized by vertical cuts that allow opening and by 4.0 metal lacquered finish. The living wall traces the same finishes as the kitchen and is characterized by an intersection of volumes that allow full and empty spaces with recessed folding open units, while the sideboard is with Vogue doors and top in thick gres.





DETTAGLIO PARETE LIVING CON ANTE BLUNA LACCATO METAL 4.0 FINITURA AMARANTO, COLONNE IN BLUNA BILAMINATO LEGNO FINITURA NOCE MONZA E MODULI A GIORNO FOLDING NERO OPACO.

DETAIL OF LIVING WITH BLUNA LACQUERED METAL 4.0 FINITION AMARANTO, COLUMNS IN BLUNA WOOD BILAMINATE NOCE MONZA FINISH AND FOLDING OPEN SPACE UNITS MATT BLACK FINISH.

DETAIL MUR LIVING AVEC FAÇADES BLUNA LAQUEES METAL 4.0 FINITION ROSSO AMARANTO, COLONNES BLUNA BILAMINE BOIS FINITION NOCE MONZA ET MEUBLES OUVERTS FOLDING NOIR MAT.

DETALLE PARED LIVING CON PUERTAS LACADO METAL 4.0 ACABADO ROJO AMARANTO, COLUMNAS BLUNA BILAMINADO DE MADERA ACABADO NOCE MONZA Y MÓDULOS ABIERTOS PLEGABLES NEGRO MATE.





DETTAGLIO MADIA IN
LACCATO METAL 4.0
FINITURA AMARANTO,
TOP IN GRES
FINITURA BRECCIA
CAPRAIA OPACO.

DETAIL OF SIDEBOARD
IN METAL 4.0
LACQUERED AMARANTO
FINISH, TOP IN MATT
GRES BRECCIA CAPRAIA
FINISH.

DETAIL OF SIDEBOARD
IN METAL 4.0
LACQUERED AMARANTO
FINISH, TOP IN MATT
GRES BRECCIA CAPRAIA
FINISH.

DETAIL OF SIDEBOARD
IN METAL 4.0
LACQUERED AMARANTO
FINISH, TOP IN MATT
GRES BRECCIA CAPRAIA
FINISH.



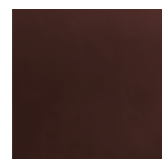

LACCATO METAL
4.0 AMARANTO



BILAMINATO
LEGNO NOCE
MONZA



GRES BRECCIA
CAPRAIA OPACO



TECH NERO ONICE
OPACO

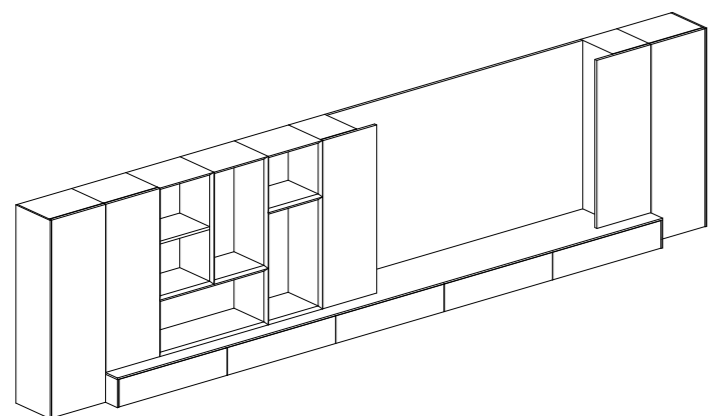

PARETE LIVING LIVING WALL

L 545 H 138 P 47,5/35,5

BLUNA LACCATO METAL 4.0 AMARANTO
BLUNA BILAMINATO LEGNO NOCE MONZA
OPEN SPACE FOLDING TECH NERO ONICE OPACO

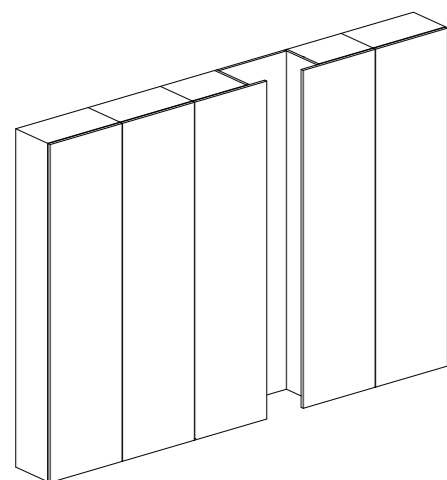

PARETE SALA DA PRANZO DINING ROOM WALL

L 330 CM H 235,5 P 35,5

BLUNA BILAMINATO LEGNO NOCE MONZA
NICCHIA LUMINOSA LACCATO METAL 4.0 AMARANTO

VOGUE + BLUNA

SCHEDA TECNICA DATA SHEET
FICHE TECHNIQUE FICHA DE DATOS

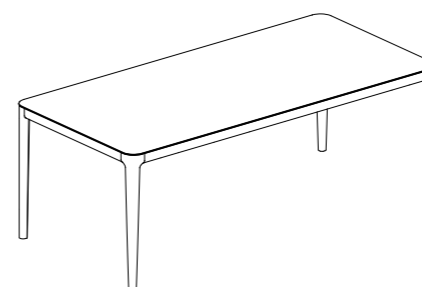

TAVOLO FIRENZE 02 TABLE

L. 210 H. 76 P. 100

TOP GRES BRECCIA CAPRAIA OPACO
STRUTTURA LEGNO FRASSINO CARBONE

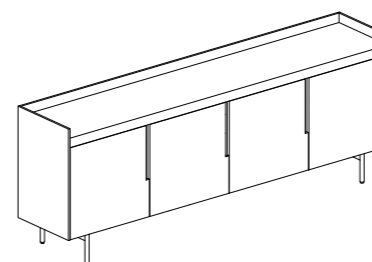

MADIA SIDEBOARD

L. 242,4 H. 90 P. 47,5

VOGUE LACCATO METAL 4.0 AMARANTO
VASSOIO CENTRALE GRES BRECCIA CAPRAIA OPACO
BASAMENTO ROUND METALLO NERO OPACO

146

147

BLUNA TECH BRUNITO



BLUNA TECH BRUNITO

149

Uno spazio puro ed elegante in cui le superfici bronzee prendono vita trasformandosi per creare differenti atmosfere in base al luogo nel quale vengono posti. L'essenzialità dei solidi, sottolineata dalle ante delle colonne e dalle basi con gola, non contrasta con le diverse materie traslucide che introducono ad innumerevoli e rigorosi riflessi. La parete living è caratterizzata da un gioco di volumi garantito per mezzo delle due profondità disponibili, in basso le basi in tech, in alto le colonne in bilaminato legno ed infine la boiserie con funzione di sostegno per la tv. La medesima contaminazione materica si ritrova nella madia dai riflessi bronzee che accompagna il tavolo tondo. A pure and elegant space in which bronze surfaces come to life, transforming themselves to create different atmospheres based on the place in which they are placed. The essentiality of the solids, emphasized by the doors of the columns and the bases with grooves, does not contrast with the different translucent materials that introduce countless and rigorous reflections. The living wall is characterized by a play of volumes guaranteed by the two available depths, the tech bases at the bottom, the bilaminate wood columns at the top and finally the boiserie with support function for the TV. The same material contamination is found in the sideboard with bronze reflections that accompanies the round table.





DETTAGLIO LIVING
CON ANTE BLUNA
TECH IN FINITURA
ALLUMINIO BRUNITO
CON PROFILO TRIM
NERO E GOLA ELLE
IN FINITURA NERO
OPACO. TOP IN
FINITURA GRES NERO
GRECO OPACO SP.
12 MM. COLONNE IN
FINITURA BILAMINATO
LEGNO NOCE CANTÙ.

DETAIL OF SIDEBOARD
WITH BLUNA TECH
DOOR ALLUMINIO
BRUNITO FINISH
WITH TRIM PROFILE
AND ELLE GROOVE IN
MATT BLACK FINISH.
WORKTOP MATT GRES
NERO GRECO FINISH
12 MM THICKNESS.
COLUMNS IN WOOD
BILAMINATE NOCE
CANTÙ FINISH.

DETAIL LIVING AVEC
FAÇADES BLUNA
TECH EN FINITION
ALUMINIUM BRUNI
AVEC PROFIL TRIM
NOIR ET GORGE
ELLE EN FINITION
NOIR MAT. PLAN DE
TRAVAIL GRES NERO
GRECO MAT EP.12MM.
COLONNES EN
FINITION BILAMINE
BOIS NOCE CANTÙ.

DETALLE PARED LIVING
CON PUERTAS BLUNA
TECH EN ACABADO DE
ALUMINIO BRUNITO
CON PERFIL TRIM
NEGRO Y GOLA ELLE EN
ACABADO NEGRO MATE.
TOP EN GRES ACABADO
NEGRO GRECO MATE
SP. 12 MM. COLUMNAS
EN ACABADO BLUNA
BILAMINADO DE
MADERA NOCE CANTÙ.

152

153

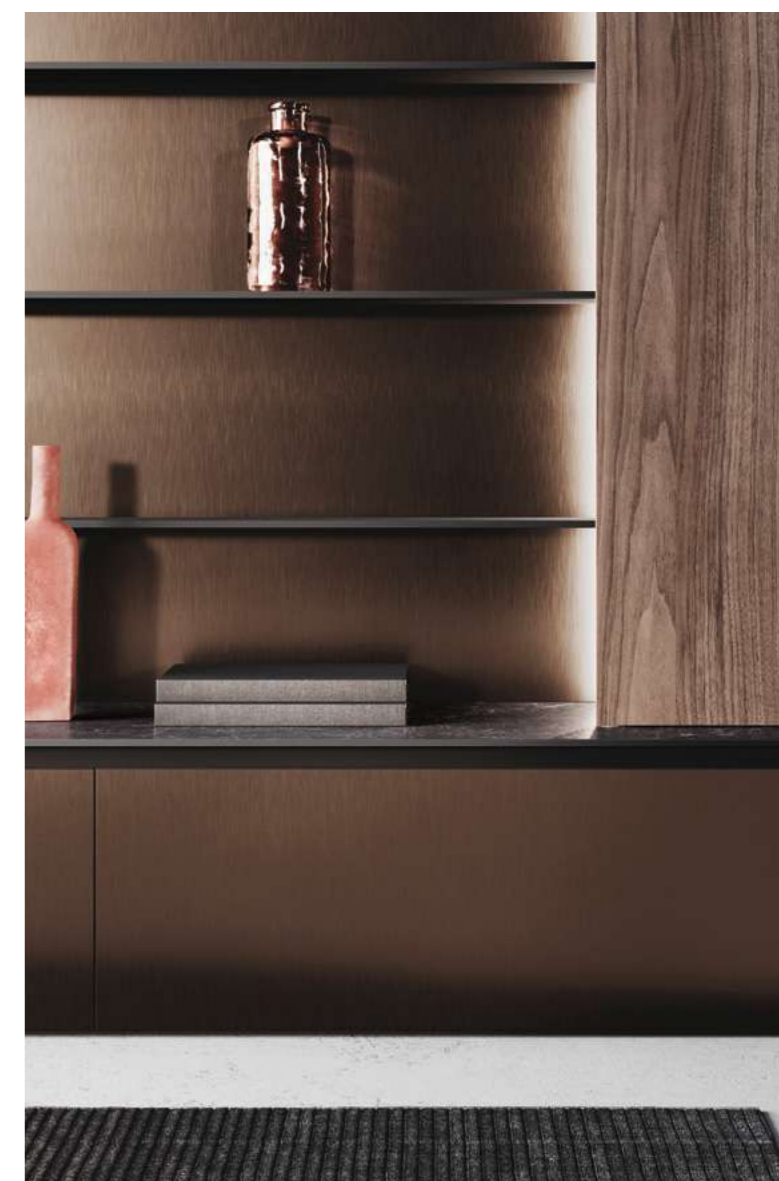

DETTAGLIO MADIA
CON ANTE BLUNA
TECH IN FINITURA
ALLUMINIO BRUNITO
CON PROFILO TRIM
NERO E GOLA ELLE IN
FINITURA NERO OPACO.
TOP IN FINITURA GRES
NERO GRECO OPACO SP.
12 MM.

DETAIL OF SIDEBOARD
WITH BLUNA TECH
DOOR ALLUMINIO
BRUNITO FINISH
WITH TRIM PROFILE
AND ELLE GROOVE IN
MATT BLACK FINISH.
WORKTOP MATT GRES
NERO GRECO FINISH
12 MM THICKNESS.

DETAIL BUFFET AVEC
FAÇADES BLUNA
TECH EN FINITION
ALUMINIUM BRUNI
AVEC PROFIL TRIM
NOIR ET GORGE ELLE
EN FINITION NOIR MAT.
PLAN DE TRAVAIL EN
FINITION GRES NERO
GRECO MAT EP.12MM.

DETALLE APARADOR
CON PUERTAS BLUNA
TECH EN ACABADO DE
ALUMINIO BRUNITO
CON PERFIL TRIM
NEGRO Y GOLA ELLE EN
ACABADO MATE NEGRO.
TOP EN GRES ACABADO
NEGRO GRECO MATE SP.
12 MM.

154

155



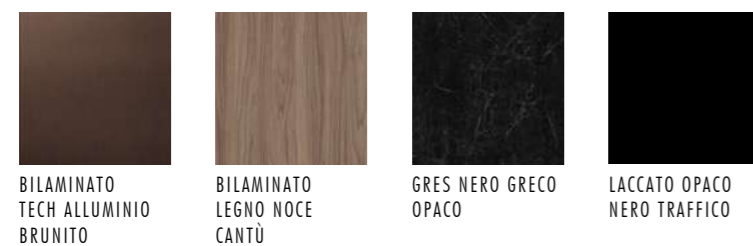

BILAMINATO
TECH ALLUMINIO
BRUNITO

BILAMINATO
LEGNO NOCE
CANTÙ

GRES NERO GRECO
OPACO

LACCATO OPACO
NERO TRAFFICO

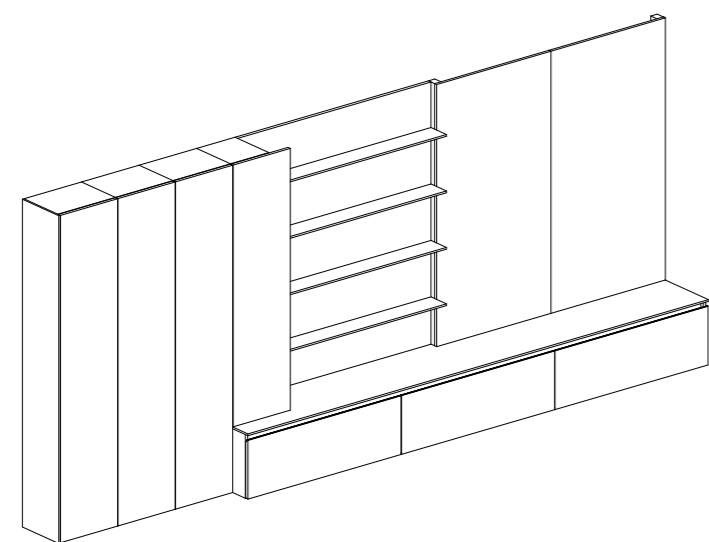

PARETE LIVING LIVING WALL

L. 495 H. 235,5 P. 47,5

BLUNA TECH ALLUMINIO BRUNITO
BLUNA BILAMINATO LEGNO NOCE CANTÙ
BOISERIE LEAF TECH ALLUMINIO BRUNITO CON MENSOLE LACCATO OPACO NERO TRAFFICO
SCHIENALE BILAMINATO LEGNO NOCE CANTÙ
TOP GRES NERO GRECO OPACO

BLUNA TECH BRUNITO

SCHEDA TECNICA DATA SHEET
FICHE TECHNIQUE FICHA DE DATOS

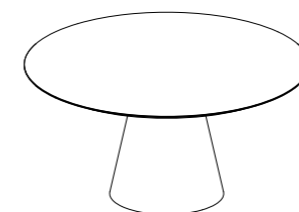

TAVOLO PISA TABLE

L. 150 H. 76 P. 150

TOP GRES NERO GRECO OPACO
STRUTTURA LEGNO NOCE CANALETTO E SOTTOPIANA
LACCATO OPACO TINTA NOCE

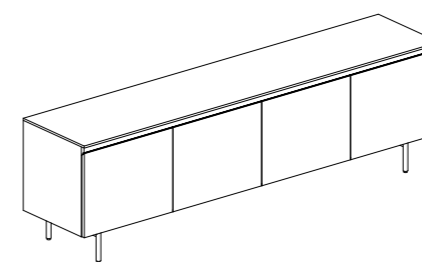

MADIA SIDEBOARD

L. 242,4 H. 85 P. 47,5

BLUNA TECH ALLUMINIO BRUNITO CON MANIGLIA TRIM NERA
TOP GRES NERO GRECO OPACO
BASAMENTO ROUND METALLO NERO OPACO

158

159

BLUNA TECH CHAMPAGNE



BLUNA

TECH CHAMPAGNE

161

Un progetto che fa riscoprire il piacere di vivere un ambiente ricco di calore. La matericità del legno naturale conferisce una gradevole sensazione estetica e tattile, le ante delle colonne in Rovere carbone sono unite al tech alluminio delle basi: un insieme di materiali ad alto contenuto tecnologico che contribuisce a creare un prodotto unico nel suo genere. La parete viene altresì arricchita dalle vetrine quadrate disposte a cassettoni e corredate da ripiani luminosi per un effetto volumetrico unico nel suo genere. La madia ripercorre gli stessi materiali ed è caratterizzata da un piano alto in gres valorizzato dalla gola e dai fianchi a tutta altezza. L'intero progetto è incentrato sul tema delle aperture speculari, le colonne si aprono per dar luogo ad uno spazio centrale atto ad ospitare vetrine e schienali in legno. A project that makes you rediscover the pleasure of living in an environment full of warmth. The materiality of natural wood gives a pleasant aesthetic and tactile sensation, the doors of the tall units in Charcoal Oak are combined with the aluminum tech of the bases: a set of high-tech materials that helps to create a unique product of its kind. The wall is also enriched by square showcases arranged in drawers and accompanied by luminous shelves for a unique volumetric effect. The sideboard traces the same materials and is characterized by a high stoneware top enhanced by the throat and full-height sides. The entire project is centered on the theme of mirrored openings, the columns open to give rise to a central space capable of hosting display cabinets and wooden backs.





DETTAGLIO PARETE LIVING CON BASI IN FINITURA TECH ALLUMINIO CHAMPAGNE, PENSILI CON ANTE VETRO REFLEX COSTITUITO DA TELAIO IN ALLUMINIO NERO E VETRO FUMÈ, SCHIENALI E COLONNE IN LEGNO FINITURA ROVERE CARBONE.

DETAIL OF BASE UNITS IN TECH ALLUMINIO CHAMPAGNE FINISH AND WALL UNITS WITH REFLEX GLASS DOORS MADE IN BLACK ALUMINIUM FRAME AND FUMÈ GLASS, BACK PANELS AND COLUMNS ARE IN WOOD ROVERE CARBONE FINISH.

DETAIL MUR LIVING AVEC MEUBLES BAS EN FINITION TECH ALUMINIUM CHAMPAGNE, MEUBLES HAUTS AVEC FAÇADES EN VERRE REFLEX COMPOSE PAR UN CADRE EN ALUMINIUM NOIR ET VERRE FUME, DOS ET COLONNES EN BOIS FINITION ROVERE CARBONE.

DETALLE PARED LIVING CON BAJOS EN ACABADO TECH ALLUMINIO CHAMPAGNE, ALTOS CON PUERTAS DE VIDRIO REFLEX MARCO EN ACABADO DE ALUMINIO NEGRO Y VIDRIO FUME', ESPALDA Y COLUMNAS ENCHAPADO DE MADERA ACABADO ROVERE CARBONE.



DETTAGLIO MADIA
CON ANTE IN
FINITURA BLUNA
TECH ALLUMINIO
CHAMPAGNE E GOLA
ELLE IN FINITURA
NERO OPACO. FIANCHI
IN FINITURA LEGNO
ROVERE CARBONE.
TOP IN FINITURA GRES
EMPERADOR OPACO.

DETAIL OF SIDEBOARD
WITH BLUNA TECH
DOORS ALUMINUM
CHAMPAGNE FINISH
AND ELLE GROOVE IN
MATT BLACK FINISH.
SIDE PANELS IN WOOD
ROVERE CARBONE
FINISH. TOP IN MATT
GRES EMPERADOR
FINISH.

DETAIL BUFFET
AVEC FAÇADES EN
FINITION BLUNA
TECH ALUMINIUM
CHAMPAGNE ET GORGE
ELLE EN FINITION NOIR
MAT. COTES DE FINITION
INTEGRES BOIS ROVERE
CARBONE. PLAN DE
TRAVAIL EN FINITION
GRES EMPERADOR MAT.

DETALLE APARADOR CON
PUERTAS DE ACABADO
BLUNA TECH ALLUMINIO
CHAMPAGNE Y GOLA
ELLE EN ACABADO
NEGRO MATE. COSTADOS
ENCHAPADOS DE MADERA
ACABADO ROVERE
CARBONE. ENCIMERA
EN GRES ACABADO
EMPERADOR OPACO.

166

167



BLUNA TECH CHAMPAGNE

SCHEDA TECNICA DATA SHEET
FICHE TECHNIQUE FICHA DE DATOS



BLUNA TECH
ALLUMINIO
CHAMPAGNE

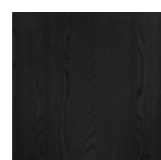

LEGNO ROVERE
CARBONE



GRES EMPERADOR
OPACO



LEGNO ROVERE
GRIGIO LONDRA



BILAMINATO
STRUTTURA NERO
CARBONE



VETRO FUMÉ E
ALLUMINIO NERO

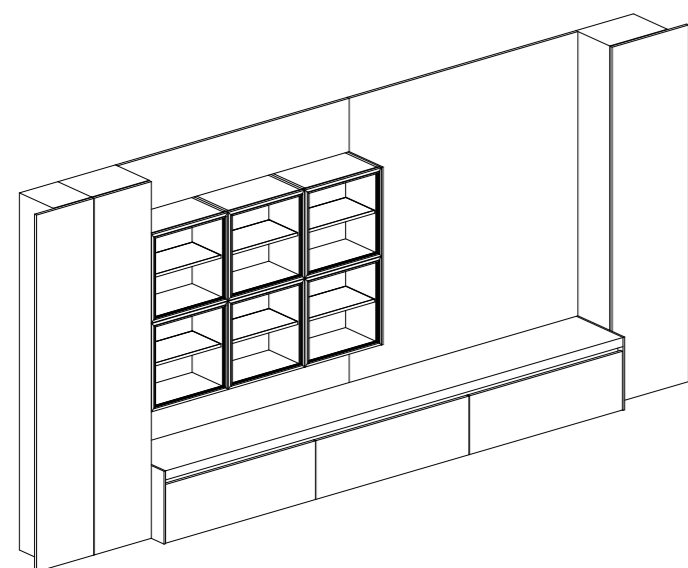

PARETE LIVING LIVING WALL

L 510 H 235,5 P 47,5/35,5

BLUNA TECH ALLUMINIO CHAMPAGNE
BLUNA LEGNO ROVERE CARBONE
VETRINE REFLEX TELAIO NERO OPACO E VETRO FUMÉ,
STRUTTURA NERO CARBONE CON RIPIANI LUMINOSI
SCHIENALE LEGNO ROVERE CARBONE
TOP GRES EMPERADOR OPACO

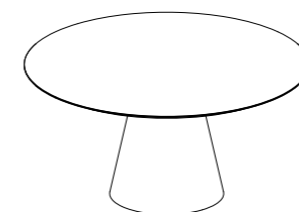

TAVOLO PISA TABLE

L. 150 H. 76 P. 150

TOP GRES EMPERADOR OPACO
STRUTTURA LEGNO NOCE CANALETTO E SOTTOPIANA
LACCATO OPACO TINTA NOCE

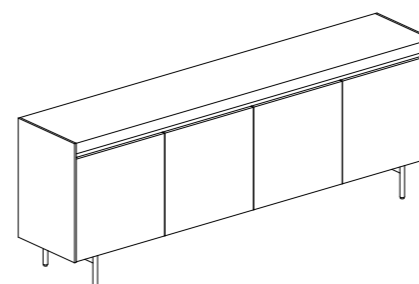

MADIA SIDEBOARD

L. 242,4 H. 89,5 P. 47,5

BLUNA TECH ALLUMINIO CHAMPAGNE
TOP GRES EMPERADOR OPACO
FIANCHI ESTERNI LEGNO ROVERE GRIGIO LONDRA
BASAMENTO ROUND METALLO NERO OPACO

170

171

FINITURE

FINISHES

TECH OPACO MATT TECH



BIANCO NORDICO OPACO



GRIGIO PIETRA OPACO



CRETA OPACO



GRIGIO ARDESIA OPACO



VERDE POLVERE OPACO



BLU PROFONDO OPACO



NERO ONICE OPACO

BLUNA

172

TECH ALLUMINIO ALUMINUM TECH



ALLUMINIO CHAMPAGNE

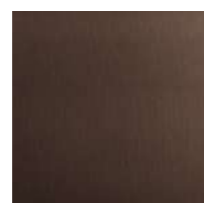

ALLUMINIO BRUNITO

BLUNA

BILAMINATO LEGNO WOOD BILAMINATE



ROVERE CHIARO



NOCE NATURALE



EUCALIPTO FUMO

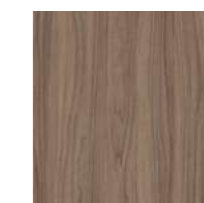

NOCE CANTÙ

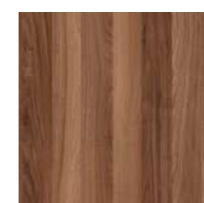

NOCE ADIGE



NOCE AMERICANO



NOCE MONZA

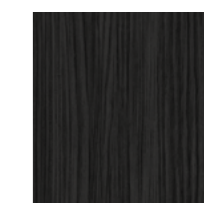

ROVERE LAVA



ROVERE QUERCIA

BLUNA

173

BILAMINATO MATERICO TEXTURAL BILAMINATE

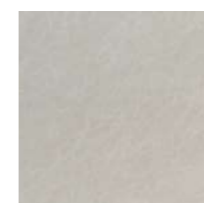

BETON ARGILLA



BETON GIOVE

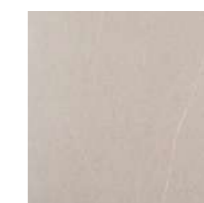

PIETRA PIASENTINA



BETON SILVER

BLUNA



BETON NUVOLE

LACCATO OPACO/LUCIDO MATT/GLOSSY LACQUERED

BLUNA SCAVA VOGUE MANTIS



TITAN WHITE



BIANCO PURO

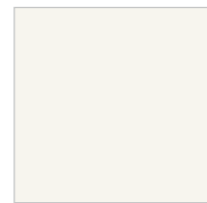

AVORIO

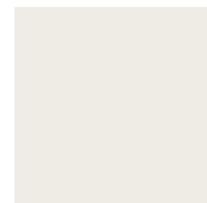

SAHARA BEIGE

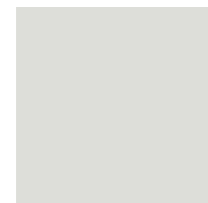

GRIGIO BOX



GRIGIO FUMO



BEIGE KENIA



CAPPUCCINO



COTONE



NOCCIOLA



GRIGIO FOSCO



GRIGIO LAVA



FERRO



CARRUBA



CAFFÈ



ROSSO TOSCA

174

175

LACCATO OPACO/LUCIDO MATT/GLOSSY LACQUERED

BLUNA SCAVA VOGUE MANTIS



ROSSO VINO



SALVIA



VERDE PASTELLO



VERDE BOSCO



BLU OCEANO



INK BLUE

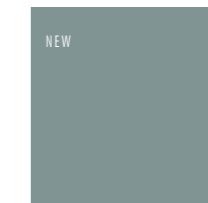

PAXOS GREY



GRIGIO ANTRACITE



NERO TRAFFICO



RAL

LAMINATO FENIX FENIX LAMINATE



BIANCO KOS

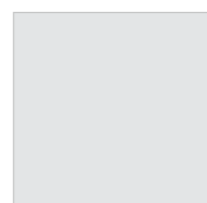

GRIGIO EFESO



CASTORO OTTAWA



GRIGIO LONDRA



VERDE COMODORO



ROSSO JAIPUR



GRIGIO BROMO



NERO INGO

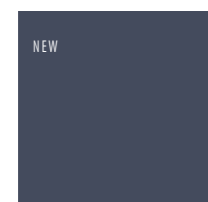

BLU FES

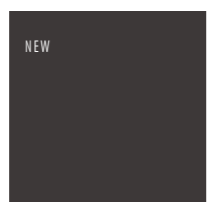

CACAO ORINOCO

LEGNO WOOD



ROVERE NATURALE
PRECOMPOSTO ALPI

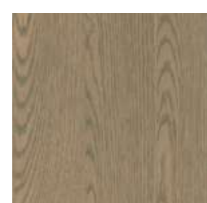

ROVERE MANHATTAN

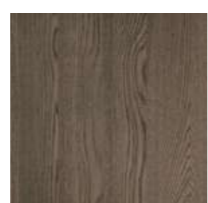

ROVERE GRIGIO PEPE

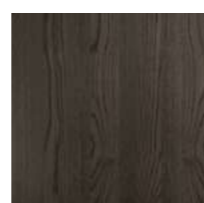

ROVERE GRIGIO LONDRA

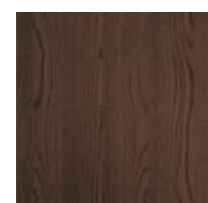

ROVERE TABACCO

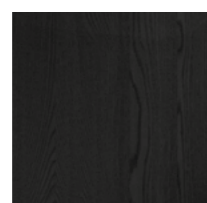

ROVERE CARBONE



ROVERE VESUVIO DOGA
SFALSATA

BLUNA WORKTOP

176

177

LEGNO SPECIALE A SPECIAL WOOD A



NOCE CANALETTO

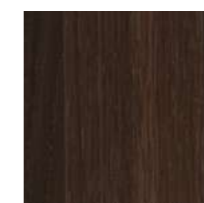

ROVERE TERMOTRATTATO

LEGNO SPECIALE B SPECIAL WOOD B

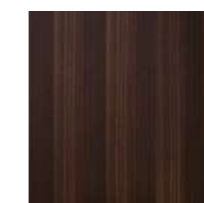

EUCALIPTO SCURO

BLUNA SCAVA VOGUE AVOLA MANTIS

BLUNA SCAVA VOGUE AVOLA

LACCATO METAL 4.0 4.0 METAL LACQUERED

BLUNA SCAVA VOGUE MANTIS



TITANIO

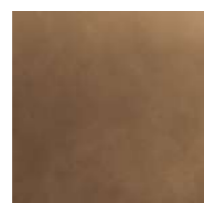

OTTONE

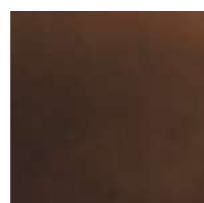

BRONZO

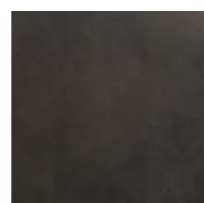

PELTRO

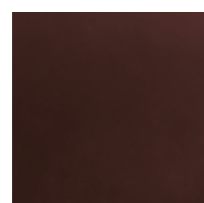

AMARANTO



FORESTA

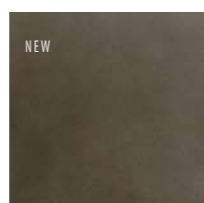

PIOMBO

178

179

LEGNO SPINA DI PESCE HERRINGBONE WOOD

MANTIS

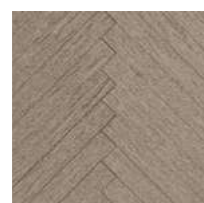

ROVERE SATURNO

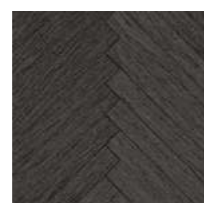

ROVERE CORTECCIA

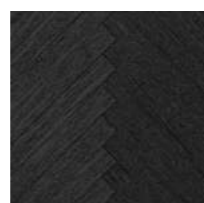

ROVERE MAGMA

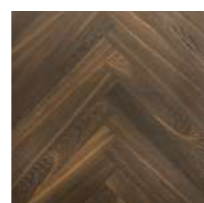

ROVERE TERMOTRATTATO

LEGNO RIGATO RIBBED WOOD

AVOLA

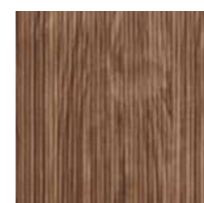

NOCE CANALETTO RIGATO

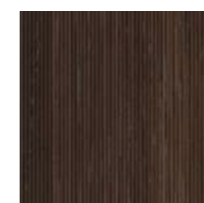

ROVERE TERMOTRATTATO RIGATO

VETRO GLASS

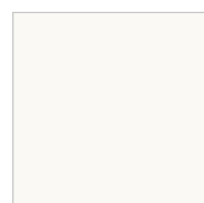

TITAN WHITE OPACO



GRIGIO BOX OPACO



BEIGE KENIA OPACO



GRIGIO ANTRACITE OPACO



NERO TRAFFICO OPACO



TITAN WHITE LUCIDO



GRIGIO BOX LUCIDO



BEIGE KENIA LUCIDO



GRIGIO ANTRACITE LUCIDO



NERO TRAFFICO LUCIDO



BRONZO OPACO



STOPSOL SPECCHIO BRONZO



STOPSOL SPECCHIO FUMÈ

LAB AVOLA

180

181

PIETRA NATURALE NATURAL STONE



BIANCO CARRARA SPAZZOLATO

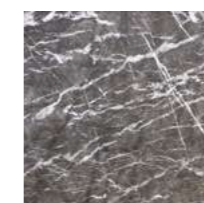

GRIGIO ALPINO SPAZZOLATO

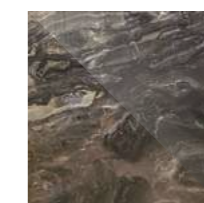

ARABESCATO OROBICO LUCIDO



BROWN EMPERADOR LUCIDO

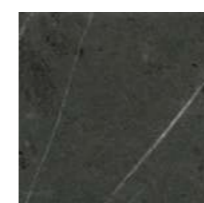

GREY STONE SPAZZOLATO



ROSSO LEVANTO LUCIDO



GRANITO NEW CAMBRIAN BLACK SPAZZOLATO

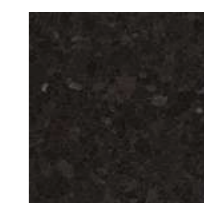

BROWN ANTIQUE SPAZZOLATO

WORKTOP

GRES

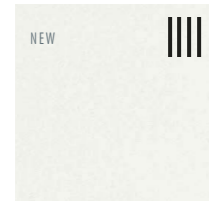

WHITE MAT



BASALTO MAT

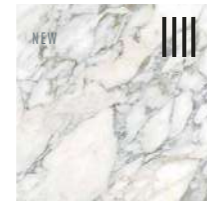

ARABESCATO ORO OPACO

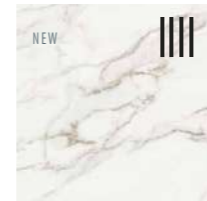

MARMORINO ORO OPACO



MARQUINA MAT



STATUARIO OPACO



STATUARIO LUCIDO

GRES



FOKOS SALE OPACO



FOKOS TERRA OPACO



FOKOS ROCCIA OPACO



FOKOS PIOMBO OPACO



CALCE TORTORA OPACO



CALCE NERO OPACO



PIETRA DI SAVOIA GRIGIA BOCCIARDATA



PIETRA DI SAVOIA ANTRACITE BOCCIARDATA



EMPERADOR OPACO



INVISIBLE WHITE OPACO

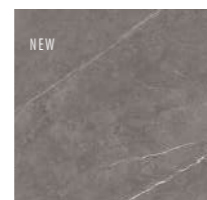

PIETRA GREY OPACO

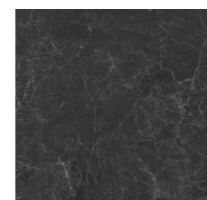

NERO GRECO OPACO

Bi-Top

AVOLA WORKTOP



MARMORINO ORO OPACO



STATUARIO LUCIDO

LAMINAM
SUPERIOR NATURAL SURFACES

AVOLA WORKTOP



FOKOS PIOMBO OPACO



PIETRA DI SAVOIA ANTRACITE BOCCIARDATA

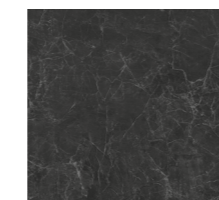

NERO GRECO OPACO

182

183

GRES



NOIR DESIR OPACO



VERDE ALPI LUCIDO



PIASENTINA GRIGIO FIAMMATO



PIASENTINA TAUPE FIAMMATO

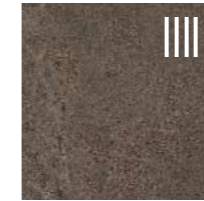

PORFIDO MARRONE FIAMMATO



TERRA DI MATERA OPACO



TERRA DI SATURNIA OPACO



TERRA DI POMPEI OPACO



CARDOSO NERO FIAMMATO

GRES



CALACATTA GOLD NAT



CALACATTA GOLD LUCIDO



PAONAZZO BIONDO SILK



OROBICO DARK LUCIDO



TAJ MAHAL SILK

LAMINAM
SUPERIOR NATURAL SURFACES

AVOLA WORKTOP



PIASENTINA TAUPE FIAMMATO



TERRA DI POMPEI OPACO

X-TONE

AVOLA WORKTOP



OROBICO DARK LUCIDO

ART DIRECTION

MAMA STUDIO

PRODUCT DESIGN

MAMA STUDIO

GRAPHIC DESIGN

MAMA STUDIO

COPY

MAMA STUDIO

RENDER

MATIC ANIMATION

COLOR SEPARATION

SINCROMIA

PRINT

SINCROMIA



The mark of
responsible forestry
FSC® C136814



Prodotti certificati FSC®
disponibili su richiesta

Binova

è un marchio Cubo Design S.r.l.

Località Case Sciarroni - Grasciano
I-64024 Notaresco - Teramo (TE) - Italy
info@cubodesign.it
www.binova.it

Cubo design S.r.l. nel perseguire una politica volta al costante miglioramento, si riserva il diritto di apportare, in qualsiasi momento e senza preavviso, le modifiche ai prodotti che riterrà utili e necessarie. L'effettiva disponibilità di quanto a catalogo deve essere verificata al momento dell'ordine. A causa di naturali limiti tecnici di riproduzione e stampa, il colore dei modelli a catalogo è puramente indicativo e non può costituire motivo di rivalsa. Cubo design S.r.l. declina ogni responsabilità per difetti e malfunzionamenti di elettrodomestici ed apparecchiature: eventuali contestazioni dovranno essere rivolte direttamente al produttore ed ai loro centri di assistenza. In order to constantly improve its products, Cubo design S.r.l. reserves the right to modify its products as it sees fit, without prior notification. The effective availability of the articles in the catalogue, must be actually checked out at the time of the order. Because of natural technical limits of the method of reproduction and printing, the colour of the models in the catalogue is purely indicative and cannot be claimed as reason for compensation and legal action. Cubo design S.r.l. every liability for defects and malfunctioning of appliances and pieces of equipment: eventual claims will have to be addressed directly to the producers and their assistance centres.